

OVERVIEW

The SM5007 series are crystal oscillator module ICs, that feature low current consumption. Highly accurate thin-film feedback resistors and high-frequency capacitors are built-in, eliminating the need for external components to make a stable fundamental-harmonic oscillator.

FEATURES

- Capacitors C_G , C_D built-in
- Standby function (oscillator stops)
- 6 μ A (typ) low standby current (5V operation)
- Power-saving pull-up resistor built-in
- Inverter amplifier feedback resistor built-in
- 3.2mA ($V_{DD} = 4.5V$), 1.6 mA ($V_{DD} = 2.7V$) drive capability
- 2.7 to 5.5V supply voltage
- Low current consumption
- Oscillator frequency output (f_O or $f_O/2$, determined by internal connection)
- 8-pin VSOP (SM5007AL \times V)
- Chip form (CF5007A \times \times)

SERIES CONFIGURATION

Version	Recommended Operating frequency ¹ [MHz]		Output frequency	gm ratio	Built-in capacitance [pF]		Input level	Output duty level	Standby output state
	3V	5V			C_G	C_D			
CF5007AA1	30	30	f_O	2	10	10	TTL	CMOS	LOW
CF5007AA2	30	30	$f_O/2$	2	10	10	TTL	CMOS	LOW
SM5007AL1V CF5007AL1	20	30	f_O	1	10	10	CMOS	CMOS	High impedance
SM5007AL2V CF5007AL2	20	30	$f_O/2$	1	10	10	CMOS	CMOS	High impedance

1. The recommended operating frequency is a yardstick value derived from the crystal used for NPC characteristics authentication. However, the oscillator frequency band is not guaranteed. Specifically, the characteristics can vary greatly due to crystal characteristics and mounting conditions, so the oscillation characteristics of components must be carefully evaluated. Since the product feature is targeted at low current consumption, please evaluate oscillation margins seriously before actual use.

ORDERING INFORMATION

Device	Package
SM5007AL \times V	8-pin VSOP
CF5007A \times \times -1	Chip form

PACKAGE DIMENSIONS

(Unit: mm)

- 8-pin VSOP

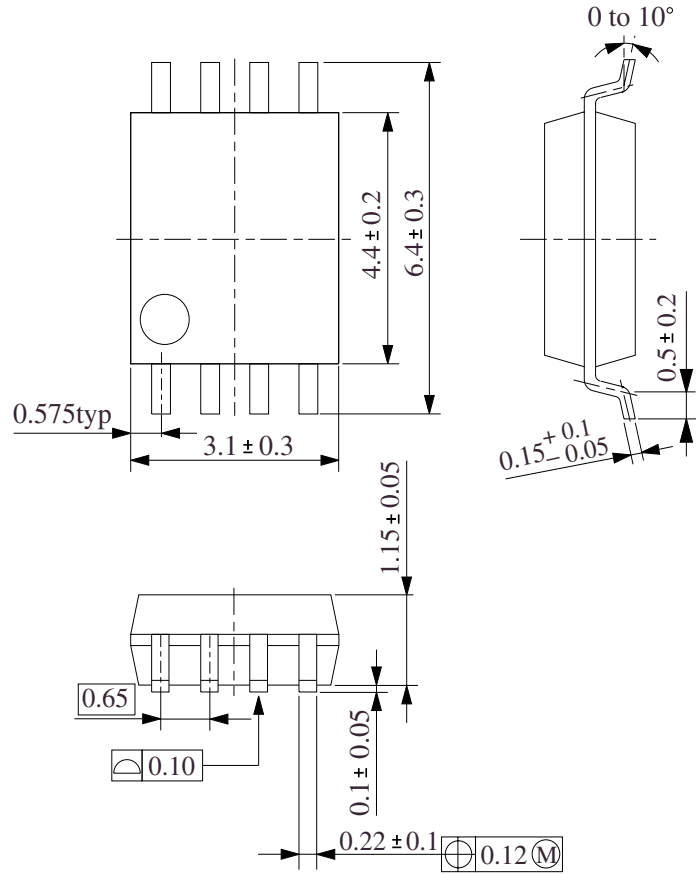

PAD LAYOUT

(Unit: μm)

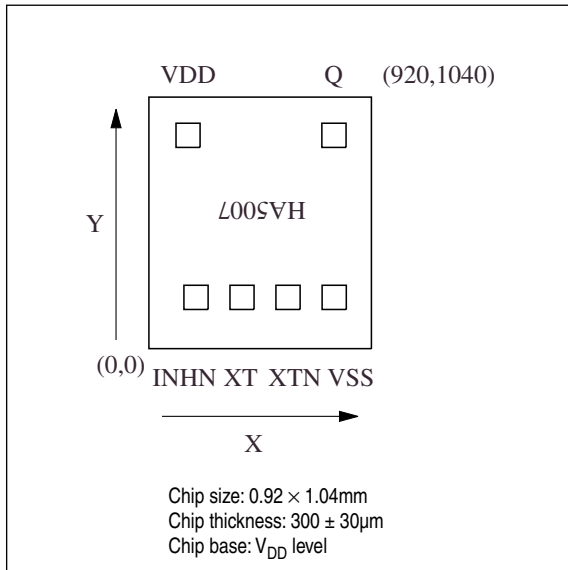

PINOUT

(Top view)

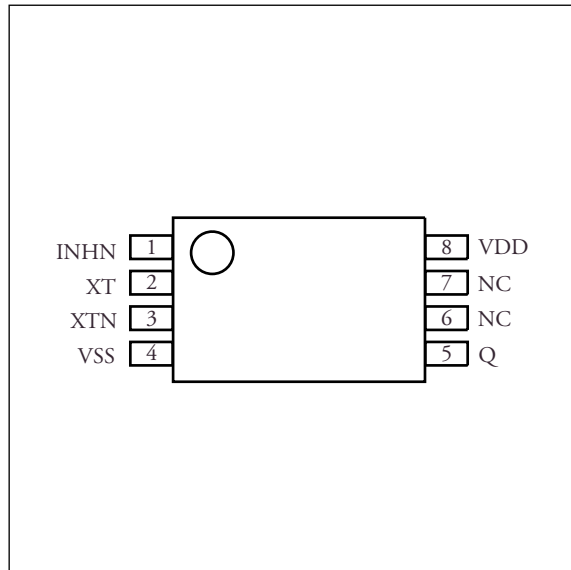

PIN DESCRIPTION and PAD DIMENSIONS

Number	Name	I/O	Description	Pad dimensions [μm]	
				X	Y
1	INHN	I	Output state control input. Oscillator stopped when LOW. Power-saving pull-up resistor built in	195	212
2	XT	I	Amplifier input.	385	212
3	XTN	O	Amplifier output.	575	212
4	VSS	-	Ground	766	212
5	Q	O	Output. Output frequency (f_0 or $f_0/2$) determined by internal connection	765	882
6	NC	-	No connection	-	-
7	NC	-	No connection	-	-
8	VDD	-	Supply voltage	162	882

BLOCK DIAGRAM

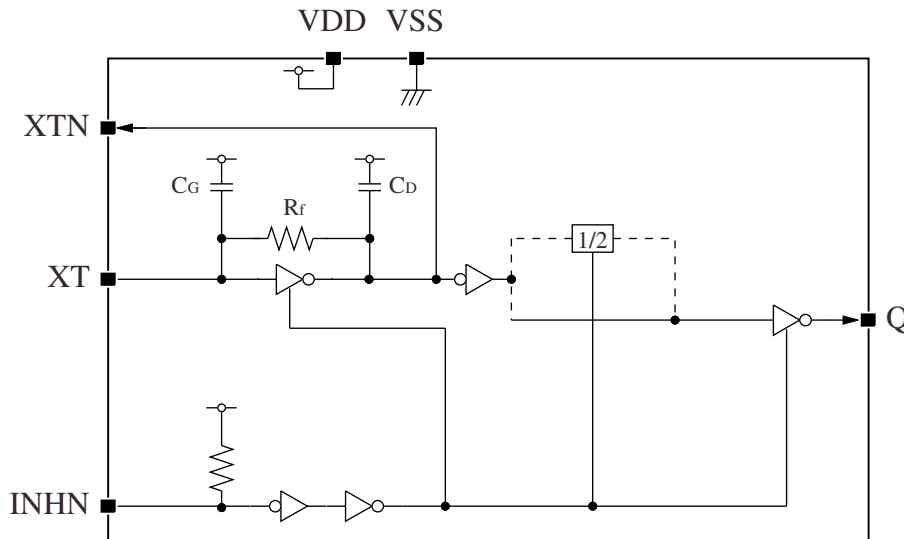

SPECIFICATIONS

Absolute Maximum Ratings

$$V_{SS} = 0V$$

Parameter	Symbol	Condition	Rating	Unit
Supply voltage range	V_{DD}		-0.5 to 7.0	V
Input voltage range	V_{IN}		-0.5 to $V_{DD} + 0.5$	V
Output voltage range	V_{OUT}		-0.5 to $V_{DD} + 0.5$	V
Operating temperature range	T_{opr}		-40 to 85	°C
Storage temperature range	T_{stg}	Chip form	-65 to 150	°C
		8-pin VSOP	-55 to 125	
Output current	I_{OUT}		15	mA
Power dissipation	P_D	8-pin VSOP	300	mW

Recommended Operating Conditions

$$V_{SS} = 0V$$

Parameter	Symbol	Condition	Rating			Unit
			min	typ	max	
Supply voltage	V_{DD}		2.7	-	5.5	V
Input voltage	V_{IN}		V_{SS}	-	V_{DD}	V
Operating temperature	T_{OPR}		-20	-	80	°C

Note: Since the recommended operating conditions will change in accordance with operating frequency, load capacitance, power dissipation, or crystal characteristics, please evaluate oscillation margins seriously before actual use.

SM5007 series

Electrical Characteristics

3V operation: $V_{DD} = 2.7$ to $3.3V$, $V_{SS} = 0V$, $T_a = -20$ to $80^\circ C$ unless otherwise noted.

Parameter	Symbol	Condition		Rating			Unit
				min	typ	max	
HIGH-level output voltage	V_{OH}	Q: Measurement cct 1, $I_{OH} = 1.6mA$		2.2	–	–	V
LOW-level output voltage	V_{OL}	Q: Measurement cct 1, $I_{OL} = 1.6mA$		–	–	0.4	V
Output leakage current (AL series only)	I_Z	Q: Measurement cct 2, INHN = LOW, $V_{OH} = V_{DD}$		–	–	10	μA
		Q: Measurement cct 2, INHN = LOW, $V_{OL} = V_{SS}$		–	–	10	
HIGH-level input voltage	V_{IH}	INHN	SM5007AL×V CF5007AL×	$0.7V_{DD}$	–	–	V
			CF5007AA×	2.0	–	–	
LOW-level input voltage	V_{IL}	INHN	SM5007AL×V CF5007AL×	–	–	$0.3V_{DD}$	V
			CF5007AA×	–	–	0.3	
Current consumption	I_{DD1}	INHN = open, Measurement cct 3, No load, $f = 30MHz$ crystal oscillator	CF5007AA1		1.8	4.8	mA
			SM5007AL1V CF5007AL1		1.2	3.2	
			CF5007AA2		1.4	3.6	
			SM5007AL2V CF5007AL2		0.8	2.0	
	I_{DD2}	INHN = open, Measurement cct 3, $C_L = 15pF$, $f = 30MHz$ crystal oscillator	CF5007AA1		3.4	6.8	
			SM5007AL1V CF5007AL1		2.8	5.2	
			CF5007AA2		2.2	4.6	
			SM5007AL2V CF5007AL2		1.6	3.0	
Standby current	I_{ST}	INHN = V_{SS} , Measurement cct 3		–	2	5	μA
INHN pull-up resistance	R_{UP1}	Measurement cct 4, $V_{DD} = 3V$, INHN = V_{SS}		0.6	–	12	$M\Omega$
	R_{UP2}	Measurement cct 4, $V_{DD} = 3V$, INHN = 2.1V		40	–	200	$k\Omega$
Negative resistance	$-R_L$	$V_{DD} = 3V$, $T_a = 25^\circ C$, 30MHz	CF5007AA×		–140		Ω
			SM5007AL×V CF5007AL×		–70		
Feedback resistance	R_f	Measurement cct 5		50	–	300	$k\Omega$
Built-in capacitance	C_G	Design value		9.3	10	10.7	pF
	C_D			9.3	10	10.7	pF

SM5007 series

5V operation: $V_{DD} = 4.5$ to $5.5V$, $V_{SS} = 0V$, $T_a = -20$ to $80^\circ C$ unless otherwise noted.

Parameter	Symbol	Condition	Rating			Unit	
			min	typ	max		
HIGH-level output voltage	V_{OH}	Q: Measurement cct 1, $I_{OH} = 3.2mA$	4.0	–	–	V	
LOW-level output voltage	V_{OL}	Q: Measurement cct 1, $I_{OL} = 3.2mA$	–	–	0.4	V	
Output leakage current (AL series only)	I_z	Q: Measurement cct 2, INHN = LOW, $V_{OH} = V_{DD}$	–	–	10	μA	
		Q: Measurement cct 2, INHN = LOW, $V_{OL} = V_{SS}$	–	–	10		
HIGH-level input voltage	V_{IH}	INHN	SM5007AL×V CF5007AL×	$0.7V_{DD}$	–	–	V
			CF5007AA×	2.0	–	–	
LOW-level input voltage	V_{IL}	INHN	SM5007AL×V CF5007AL×	–	–	$0.3V_{DD}$	V
			CF5007AA×	–	–	0.8	
Current consumption	I_{DD1}	INHN = open, Measurement cct 3, No load, $f = 30MHz$ crystal oscillator	CF5007AA1		3.0	6.8	mA
			SM5007AL1V CF5007AL1		2.2	4.8	
			CF5007AA2		2.2	5.0	
			SM5007AL2V CF5007AL2		1.4	3.0	
	I_{DD2}	INHN = open, Measurement cct 3, $C_L = 15pF$, $f = 30MHz$ crystal oscillator	CF5007AA1		5.6	9.8	
			SM5007AL1V CF5007AL1		4.8	7.8	
			CF5007AA2		3.6	6.6	
			SM5007AL2V CF5007AL2		2.8	4.6	
Standby current	I_{ST}	INHN = V_{SS} , Measurement cct 3	–	6	15	μA	
INHN pull-up resistance	R_{UP1}	Measurement cct 4, $V_{DD} = 5V$, INHN = V_{SS}	0.3	–	6	$M\Omega$	
	R_{UP2}	Measurement cct 4, $V_{DD} = 5V$, INHN = $3.5V$	40	–	200	$k\Omega$	
Negative resistance	$-R_L$	$V_{DD} = 5V$, $T_a = 25^\circ C$, $30MHz$	CF5007AA×		–360	Ω	
			SM5007AL×V CF5007AL×		–190		
Feedback resistance	R_f	Measurement cct 5	50	–	300	$k\Omega$	
Built-in capacitance	C_G	Design value	9.3	10	10.7	pF	
	C_D		9.3	10	10.7	pF	

Switching Characteristics

3V operation: $V_{DD} = 2.7$ to $3.3V$, $V_{SS} = 0V$, $T_a = -20$ to $80^\circ C$ unless otherwise noted.

Parameter	Symbol	Condition	Rating			Unit	
			min	typ	max		
Output rise time	t_r	Measurement cct 2, load cct 1, $0.1V_{DD}$ to $0.9V_{DD}$, $C_L = 15pF$	–	5	15	ns	
Output fall time	t_f	Measurement cct 2, load cct 1, $0.9V_{DD}$ to $0.1V_{DD}$, $C_L = 15pF$	–	5	15	ns	
Output duty cycle ¹	Duty	Measurement cct 2, load cct 1, $T_a = 25^\circ C$, $V_{DD} = 3V$, $C_L = 15pF$	$f_O = 16MHz$	45	–	55	%
			$f_O = 30MHz$	40	–	60	
Output disable delay time	t_{PLZ}	Measurement cct 6, load cct 1, $T_a = 25^\circ C$, $V_{DD} = 3V$, $C_L \leq 15pF$	–	–	100	ns	
Output enable delay time ²	t_{PZL}		–	–	100	ns	
Maximum operating frequency	f_{max}	Measurement cct 2, load cct 1, $C_L \leq 15pF$	30	–	–	MHz	
Minimum operating frequency	f_{min}	Measurement cct 2, load cct 1, $C_L \leq 15pF$	–	–	4	MHz	

1. The duty cycle characteristic is checked the sample chips of each production lot.
2. Oscillator stop function is built-in. When INHN goes LOW, normal output stops. When INHN goes HIGH, normal output is not resumed until after the oscillator start-up time has elapsed.

5V operation: $V_{DD} = 4.5$ to $5.5V$, $V_{SS} = 0V$, $T_a = -20$ to $80^\circ C$ unless otherwise noted.

Parameter	Symbol	Condition	Rating			Unit
			min	typ	max	
Output rise time	t_r	Measurement cct 2, load cct 1, $0.1V_{DD}$ to $0.9V_{DD}$, $C_L = 15pF$	–	3	9	ns
Output fall time	t_f	Measurement cct 2, load cct 1, $0.9V_{DD}$ to $0.1V_{DD}$, $C_L = 15pF$	–	3	9	ns
Output duty cycle ¹	Duty	Measurement cct 2, load cct 1, $T_a = 25^\circ C$, $V_{DD} = 5V$, $C_L = 15pF$	45	–	55	%
Output disable delay time	t_{PLZ}	Measurement cct 6, load cct 1, $T_a = 25^\circ C$, $V_{DD} = 5V$, $C_L \leq 15pF$	–	–	100	ns
Output enable delay time ²	t_{PZL}		–	–	100	ns
Maximum operating frequency	f_{max}	Measurement cct 2, load cct 1, $C_L \leq 15pF$	30	–	–	MHz
Minimum operating frequency	f_{min}	Measurement cct 2, load cct 1, $C_L \leq 15pF$	–	–	4	MHz

1. The duty cycle characteristic is checked the sample chips of each production lot.
2. Oscillator stop function is built-in. When INHN goes LOW, normal output stops. When INHN goes HIGH, normal output is not resumed until after the oscillator start-up time has elapsed.

Current consumption and Output waveform with NPC's standard crystal

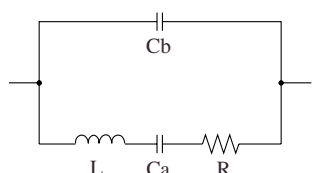

f [MHz]	R [Ω]	L [mH]	Ca [fF]	Cb [pF]
30	17.2	4.36	6.46	2.26

FUNCTIONAL DESCRIPTION

Standby Function

The oscillator stops when INHN goes LOW. When the oscillator stops, the oscillator output on Q changes as shown in the following table.

INHN	Q	Oscillator
HIGH (or open)	f_0 or $f_0/2$ output frequency	Normal operation
LOW	AA series : LOW AL series : High impedance	Stopped

Power-saving Pull-up Resistor

The INHN pull-up resistance changes in response to the input level (HIGH or LOW). When INHN goes LOW (standby state), the pull-up resistance becomes large to reduce the current consumption during standby.

MEASUREMENT CIRCUITS

Measurement cct 1

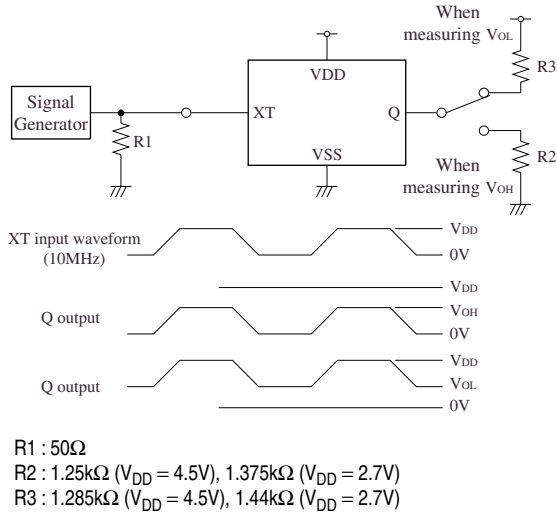

Measurement cct 4

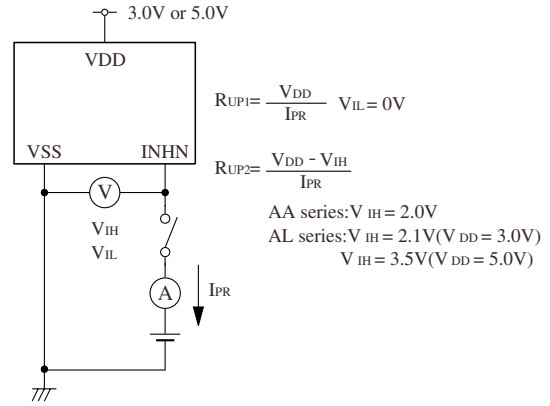

Measurement cct 2

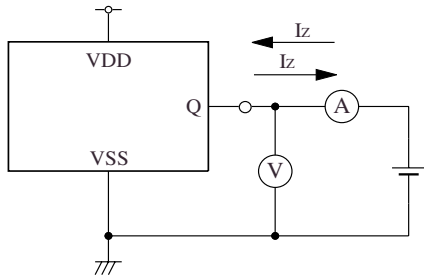

Measurement cct 5

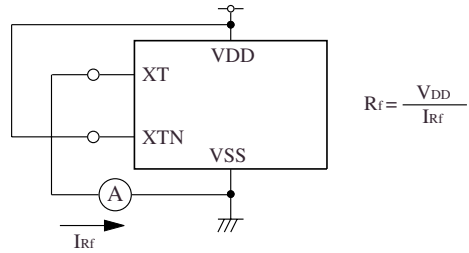

Measurement cct 3

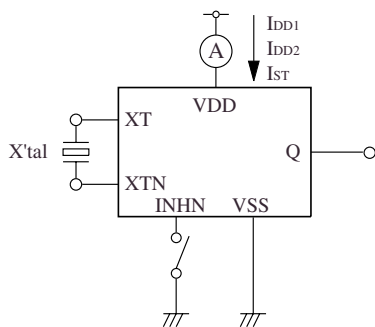

Measurement cct 6

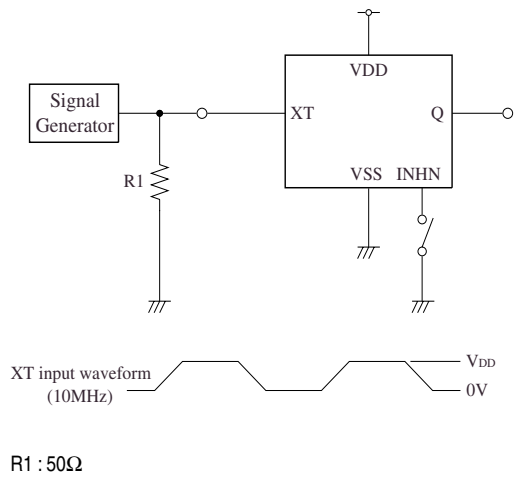

Load cct 1

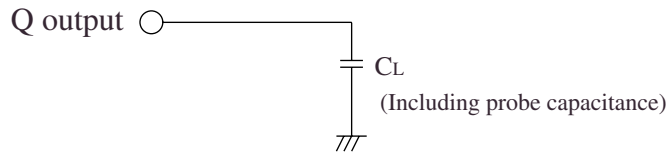

Switching Time Measurement Waveform

Output duty level (CMOS)

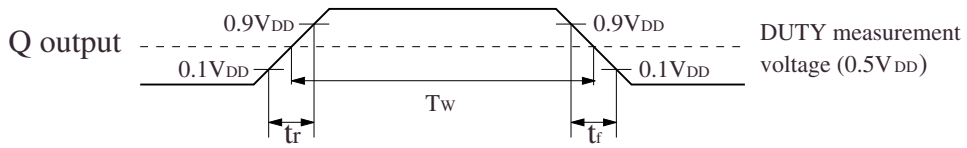

Output duty cycle (CMOS)

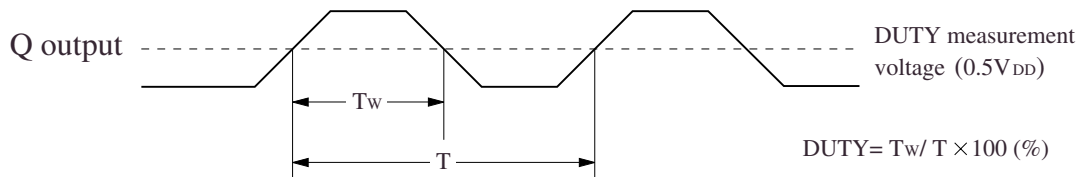

Output Enable/Disable Delay

The following figure shows the oscillator timing during normal operation. Note that when the device is in standby, the oscillator stops. When standby is released, the oscillator starts and stable oscillator output occurs after a short delay.

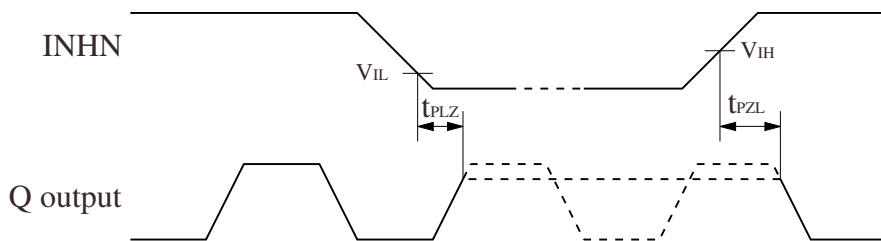

INHN input waveform $t_r = t_f \leq 10\text{ns}$

Please pay your attention to the following points at time of using the products shown in this document.

The products shown in this document (hereinafter "Products") are not intended to be used for the apparatus that exerts harmful influence on human lives due to the defects, failure or malfunction of the Products. Customers are requested to obtain prior written agreement for such use from SEIKO NPC CORPORATION (hereinafter "NPC"). Customers shall be solely responsible for, and indemnify and hold NPC free and harmless from, any and all claims, damages, losses, expenses or lawsuits, due to such use without such agreement. NPC reserves the right to change the specifications of the Products in order to improve the characteristic or reliability thereof. NPC makes no claim or warranty that the contents described in this document dose not infringe any intellectual property right or other similar right owned by third parties. Therefore, NPC shall not be responsible for such problems, even if the use is in accordance with the descriptions provided in this document. Any descriptions including applications, circuits, and the parameters of the Products in this document are for reference to use the Products, and shall not be guaranteed free from defect, inapplicability to the design for the mass-production products without further testing or modification. Customers are requested not to export or re-export, directly or indirectly, the Products to any country or any entity not in compliance with or in violation of the national export administration laws, treaties, orders and regulations. Customers are requested appropriately take steps to obtain required permissions or approvals from appropriate government agencies.

The logo for NPC (Seiko NPC Corporation) consists of the letters 'NPC' in a bold, black, sans-serif font. The 'N' and 'P' are connected at the top, and the 'C' is positioned to the right of the 'P'.

SEIKO NPC CORPORATION

15-6, Nihombashi-kabutocho, Chuo-ku,
Tokyo 103-0026, Japan
Telephone: +81-3-6667-6601
Facsimile: +81-3-6667-6611
<http://www.npc.co.jp/>
Email: sales@npc.co.jp

NC9703FE 2006.04