

## Overview

The SM5859 is a compression and non compression type anti-shock memory controller LSI for compact disc players. The compression level can be set in 4 levels, and external memory can be selected

from 4 options (1M, 1M×2, 4M, 4M×2). Digital attenuator, soft mute and related functions are also incorporated. It operates from a 2.7 to 5.5 V wide supply voltage range.

## Features

- 2-channel processing
- Serial data input
  - 2s complement, 16-bit/MSB first, rear-packed format
- System clock input
  - 384fs (16.9344 MHz)
- Anti-shock memory controller
- ADPCM compression method
  - 4-level compression mode selectable
    - 4-bit compression mode 2.78 s/Mbit
    - 5-bit compression mode 2.22 s/Mbit
    - 6-bit compression mode 1.85 s/Mbit
    - Full-bit non compression mode 0.74 s/Mbit
  - 4 external DRAM configurations selectable
    - 2×4M DRAM (1M×4 bits)
    - 1×4M DRAM (1M×4 bits)
    - 2×1M DRAM (256K×4 bits)
    - 1×1M DRAM (256K×4 bits)
- Compression mode selectable
- Microcontroller interface
  - Serial command write and state read-out
  - Data residual quantity detector:
    - 15-bit operation, 16-bit output
- Digital attenuator
  - Full-bit setting
- Soft attenuator function
  - Noiseless attenuation-level switching (256- step switching in 23 ms max.)
- Soft mute function
  - Mute ON in 23 ms max.
  - Direct return after soft mute release
- Forced mute
- Extension I/O
  - Microcontroller interface for external control using 5 extension I/O pins
- +2.7 to +5.5 V wide operating voltage range
- Schmitt inputs
  - All input pins (including I/O pins) except CLK (system clock)
- Reset signal noise elimination
  - Approximately 3.8 μs or longer (65 system clock pulses) continuous LOW-level reset
- 44-pin QFP package (0.8 mm pin pitch)

**Package dimensions** (Unit: mm)

44-pin QFP 1

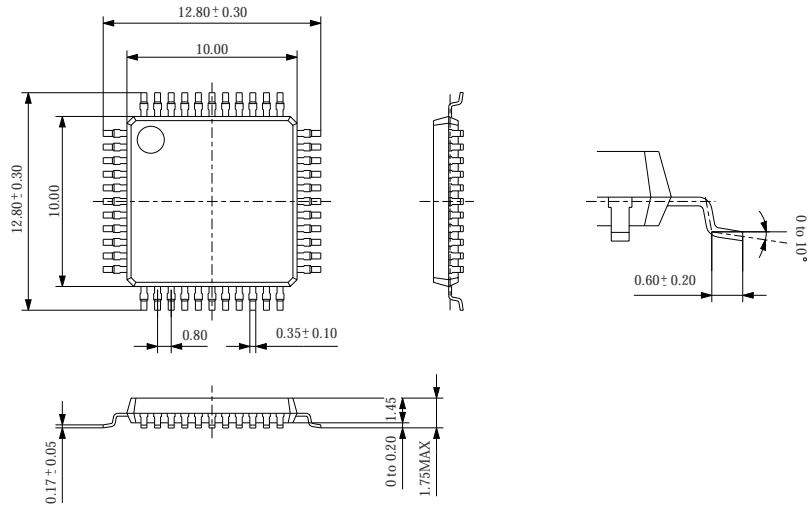

44-pin QFP 2

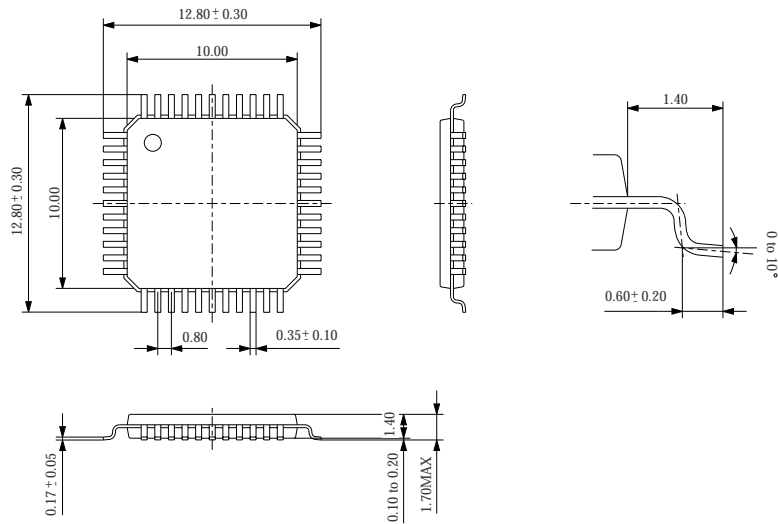

**Pinout** (Top View)

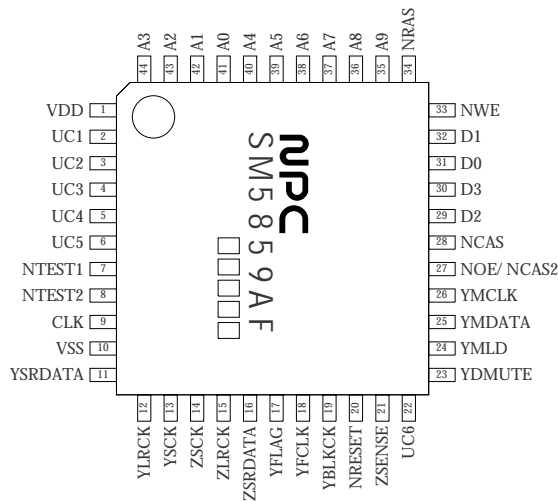

## Pin description

Pin number	Pine name	I/O	Function	Setting	
				H	L
1	VDD	-	VDD supply pin		
2	UC1	Ip/O	Microcontroller interface extension I/O 1		
3	UC2	Ip/O	Microcontroller interface extension I/O 2		
4	UC3	Ip/O	Microcontroller interface extension I/O 3		
5	UC4	Ip/O	Microcontroller interface extension I/O 4		
6	UC5	Ip/O	Microcontroller interface extension I/O 5		
7	NTEST1	Ip	Test pin		Test
8	NTEST2	Ip	Test pin		Test
9	CLK	I	16.9344 MHz clock input		
10	VSS	-	Ground		
11	YSRDATA	I	Audio serial input data		
12	YLRCK	I	Audio serial input LR clock	Left channel	Right channel
13	YSCK	I	Audio serial input bit clock		
14	ZSCK	O	Audio serial output bit clock		
15	ZLRCK	O	Audio serial output LR clock	Left channel	Right channel
16	ZSRDATA	O	Audio serial output data		
17	YFLAG	I	Signal processor IC RAM overflow flag		Overflow
18	YFCLK	I	Crystal-controlled frame clock		
19	YBLKCK	I	Subcode block clock signal		
20	NRESET	I	System reset pin		Reset
21	ZSENSE	O	Microcontroller interface status output		
22	UC6	Ip/O	Microcontroller interface extension I/O 6		
23	YDMUTE	I	Forced mute pin	Mute	
24	YMLD	I	Microcontroller interface latch clock		
25	YMDATA	I	Microcontroller interface serial data		
26	YMCLK	I	Microcontroller interface shift clock		
27	NOE (NCAS2)	O	DRAM $\overline{OE}$ control (with single DRAM)		
		O	DRAM2 $\overline{CAS}$ control (with 2 DRAMs)		
28	NCAS	O	DRAM $\overline{CAS}$ control		
29	D2	I/O	DRAM data input/output 2		
30	D3	I/O	DRAM data input/output 3		
31	D0	I/O	DRAM data input/output 0		
32	D1	I/O	DRAM data input/output 1		
33	NWE	O	DRAM $\overline{WE}$ control		
34	NRAS	O	DRAM $\overline{RAS}$ control		
35	A9	O	DRAM address 9		
36	A8	O	DRAM address 8		
37	A7	O	DRAM address 7		
38	A6	O	DRAM address 6		
39	A5	O	DRAM address 5		
40	A4	O	DRAM address 4		
41	A0	O	DRAM address 0		
42	A1	O	DRAM address 1		
43	A2	O	DRAM address 2		
44	A3	O	DRAM address 3		

Ip : Input pin with pull-up resistor Ip/O : Input/Output pin (With pull-up resistor when a input mode)

## Absolute maximum ratings

(VSS = 0V, VDD pin voltage = VDD)

Parameter	Symbol	Rating	Unit
Supply voltage	V <sub>DD</sub>	- 0.3 to 7.0	V
Input voltage	V <sub>I</sub>	V <sub>SS</sub> - 0.3 to V <sub>DD</sub> + 0.3	V
Storage temperature	T <sub>STG</sub>	- 55 to 125	°C
Power dissipation	P <sub>D</sub>	350	mW
Soldering temperature	T <sub>SLD</sub>	255	°C
Soldering time	t <sub>SLD</sub>	10	sec

(\*1) Refer to pin summary on the next page.

Note. Values also apply for supply inrush and switch-off.

## Electrical characteristics

### Recommended operating conditions

(VSS = 0V, VDD pin voltage = VDD)

Parameter	Symbol	Rating	Unit
Supply voltage	V <sub>DD</sub>	2.7 to 5.5	V
Operating temperature	T <sub>OPR</sub>	- 40 to 85	°C

## DC characteristics

Standard voltage: (VDD = 4.5 to 5.5 V, VSS = 0 V, Ta = - 40 to 85 °C)

Parameter	Pin	Symbol		Condition	Rating			Unit
					Min	Typ	Max	
Current consumption	VDD	I <sub>DD</sub>		(*A)SHPRF ON		6.5	13.0	mA
				(*A)Through mode		4.0	6.0	mA
Input voltage	CLK	H level	V <sub>IH1</sub>		0.7V <sub>DD</sub>			V
		L level	V <sub>IL1</sub>			0.3V <sub>DD</sub>		V
			V <sub>INAC</sub>	AC coupling	0.3			V <sub>P-P</sub>
	(*2,3,4)	H level	V <sub>IH2</sub>		0.7V <sub>DD</sub>			V
		L level	V <sub>IL2</sub>				0.3V <sub>DD</sub>	V
	(*5)	H level	V <sub>IH3</sub>		0.6V <sub>DD</sub>			V
L level		V <sub>IL3</sub>				0.2V <sub>DD</sub>	V	
Output voltage	(*4,6)	H level	V <sub>OH1</sub>	I <sub>OH</sub> = - 0.5 mA	V <sub>DD</sub> - 0.4			V
		L level	V <sub>OL1</sub>	I <sub>OL</sub> = 0.5 mA			0.4	V
	(*5,7)	H level	V <sub>OH2</sub>	I <sub>OH</sub> = - 0.5 mA	V <sub>DD</sub> - 0.4			V
		L level	V <sub>OL2</sub>	I <sub>OL</sub> = 0.5 mA			0.4	V
Input current	CLK		I <sub>IH1</sub>	V <sub>IN</sub> = V <sub>DD</sub>	40	95	190	μA
			I <sub>IL1</sub>	V <sub>IN</sub> = 0V	40	95	190	μA
	(*3,4)	I <sub>IL2</sub>	V <sub>IN</sub> = 0V	6	12	25	μA	
Input leakage current	(*2,3,4,5)		I <sub>LH1</sub>	V <sub>IN</sub> = V <sub>DD</sub>			1.0	μA
	(*2,5)		I <sub>LL</sub>	V <sub>IN</sub> = 0V			1.0	μA

(\*A) VDD = 5 V, CLK input frequency f<sub>XTI</sub> = 384fs = 16.9344 MHz, all outputs unloaded,  
 SHPRF: Shock-proof,  
 typical values are for VDD = 5 V.

## SM5859AF

**Low-voltage:(VDD = 2.7 to 4.5 V, VSS = 0 V, Ta = - 20 to 70 °C)**

Parameter	Pin	Symbol		Condition	Rating			Unit
					Min	Typ	Max	
Current consumption	VDD	IDD		(*B)SHPRF ON		4.0	8.0	mA
				(*B)Through mode		1.6	2.4	mA
Input voltage	CLK	H level	V <sub>IH1</sub>		0.7V <sub>DD</sub>			V
		L level	V <sub>IL1</sub>			0.3V <sub>DD</sub>		V
			V <sub>INAC</sub>	AC coupling	0.3			V <sub>P-P</sub>
	(*2,3,4)	H level	V <sub>IH2</sub>		0.7V <sub>DD</sub>			V
		L level	V <sub>IL2</sub>				0.3V <sub>DD</sub>	V
	(*5)	H level	V <sub>IH3</sub>		0.6V <sub>DD</sub>			V
		L level	V <sub>IL3</sub>				0.2V <sub>DD</sub>	V
	Output voltage	(*4,6)	H level	V <sub>OH1</sub>	I <sub>OH</sub> = - 0.5 mA	V <sub>DD</sub> - 0.4		
L level			V <sub>OL1</sub>	I <sub>OL</sub> = 0.5 mA			0.4	V
(*5,7)		H level	V <sub>OH2</sub>	I <sub>OH</sub> = - 0.5 mA	V <sub>DD</sub> - 0.4			V
		L level	V <sub>OL2</sub>	I <sub>OL</sub> = 0.5 mA			0.4	V
Input current	CLK	I <sub>IH1</sub>	V <sub>IN</sub> = V <sub>DD</sub>	15	30	115	μA	
		I <sub>IL1</sub>	V <sub>IN</sub> = 0V	15	30	115	μA	
	(*3,4)	I <sub>IL2</sub>	V <sub>IN</sub> = 0V	1.5	3	15	μA	
Input leakage current	(*2,3,4,5)	I <sub>LH1</sub>	V <sub>IN</sub> = V <sub>DD</sub>			1.0	μA	
	(*2,5)	I <sub>LL</sub>	V <sub>IN</sub> = 0V			1.0	μA	

(\*B) VDD = 3 V, CLK input frequency  $f_{XT1} = 384fs = 16.9344$  MHz, all outputs unloaded,  
SHPRF: Shock-proof,  
typical values are for VDD = 3 V.

### <Pin summary>

(*1)	Pin function	Clock input pin (AC input)
	Pin name	CLK
(*2)	Pin function	Schmitt input pins
	Pin name	YSRDATA, YLRCK, YSCK, YFLAG, YFCLK, NRESET, YBLKCK, YDMUTE, YMLD, YMDATA, YMCLK
(*3)	Pin function	Schmitt input pin with pull-up
	Pin name	NTEST1, NTEST2
(*4)	Pin function	I/O pins (Schmitt input with pull-up in input state)
	Pin name	UC1, UC2, UC3, UC4, UC5, UC6
(*5)	Pin function	I/O pins (Schmitt input in input state)
	Pin name	D0, D1, D2, D3
(*6)	Pin function	Outputs
	Pin name	ZSCK, ZLRCK, ZSRDATA, ZSENSE
(*7)	Pin function	Outputs
	Pin name	NOE, NCAS, NWE, NRAS, A0, A1, A2, A3, A4, A5, A6, A7, A8, A9

**AC characteristics**

Standard voltage: VDD = 4.5 to 5.5 V, VSS = 0 V, Ta = -40 to 85 °C

Low-voltage: VDD = 2.7 to 4.5 V, VSS = 0 V, Ta = -20 to 70 °C

(\*) Typical values are for fs = 44.1 kHz

**System clock (CLK pin)**

Parameter	Symbol	Condition System clock	Rating			Unit
			Min	Typ	Max	
Clock pulsewidth (HIGH level)	t <sub>CWH</sub>		26	29.5	125	ns
Clock pulsewidth (LOW level)	t <sub>CWL</sub>		26	29.5	125	ns
Clock pulse cycle	t <sub>CY</sub>	384fs	56	59	250	ns

System clock input

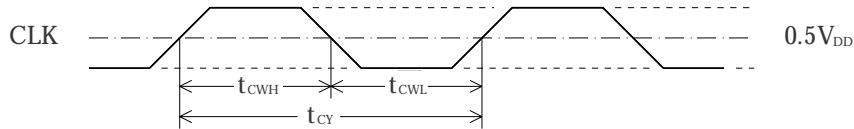

**Serial input (YSRDATA, YLRCK, YSCK pins)**

Parameter	Symbol	Rating			Unit	Condition
		Min	Typ	Max		
YSCK pulsewidth (HIGH level)	t <sub>BCWH</sub>	75			ns	
YSCK pulsewidth (LOW level)	t <sub>BCWL</sub>	75			ns	
YSCK pulse cycle	t <sub>BCY</sub>	150			ns	
YSRDATA setup time	t <sub>DS</sub>	40			ns	
YSRDATA hold time	t <sub>DH</sub>	40			ns	
Last YSCK rising edge to YLRCK edge	t <sub>BL</sub>	40			ns	
YLRCK edge to first YSCK rising edge	t <sub>LB</sub>	40			ns	
YLRCK pulse frequency See note below.		0		2fs		Memory system ON (MSON=H)
		fs		fs		Memory system OFF (MSON=L)

Note. When the memory system is OFF (through mode), the input data rate is synchronized to the system clock input (384fs), so input data needs to be at 1/384 of this frequency. But, this IC can tolerate a certain amount of jitter. For details, refer to Through-mode operation.

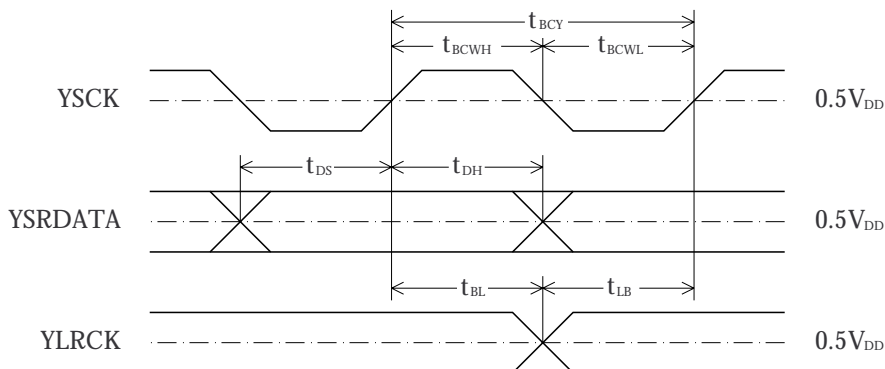

Microcontroller interface (YMCLK, YMDATA, YMLD, ZSENSE pins)

Parameter	Symbol	Rating			Unit
		Min	Typ	Max	
YMCLK LOW-level pulsewidth	$t_{MCWL}$	$30 + 3t_{CY}$			ns
YMCLK HIGH-level pulsewidth	$t_{MCWH}$	$30 + 3t_{CY}$			ns
YMDATA setup time	$t_{MDS}$	$30 + t_{CY}$			ns
YMDATA hold time	$t_{MDH}$	$30 + t_{CY}$			ns
YMLD LOW-level pulsewidth	$t_{MLWL}$	$30 + 3t_{CY}$			ns
YMLD setup time	$t_{MLS}$	$30 + t_{CY}$			ns
YMLD hold time	$t_{MLH}$	$30 + t_{CY}$			ns
Rise time	$t_r$			100	ns
Fall time	$t_f$			100	ns
ZSENSE output delay	$t_{PZS}$			$100 + 3t_{CY}$	ns

Note.  $t_{CY}$  is the system clock cycle time (59ns typ).

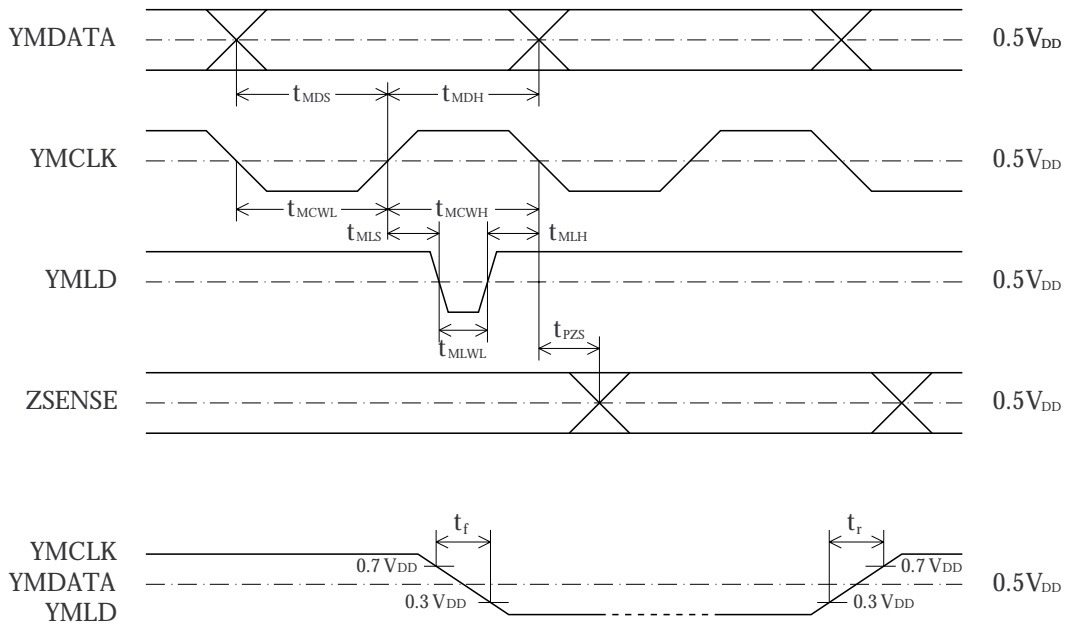

Reset input (NRESET pin)

Parameter	Symbol	Rating			Unit
		Min	Typ	Max	
First HIGH-level after supply voltage rising edge	$t_{HNRST}$	0			$t_{CY}$ (Note)
NRESET pulsewidth	$t_{NRST}$	64			$t_{CY}$ (Note)

Note.  $t_{CY}$  is the system clock (CLK) input (384fs) cycle time.

$t_{CY} = 59 \text{ ns}$ ,  $t_{NRST} (\text{min}) = 3.8 \mu\text{s}$  when  $f_s = 44.1 \text{ kHz}$

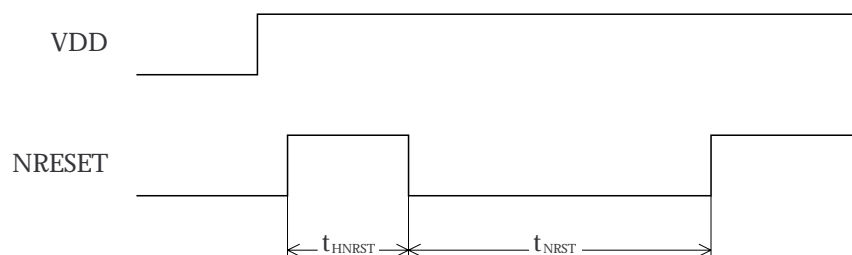

# SM5859AF

## Serial output (ZSRDATA, ZLRCK, ZSCK pins)

Parameter	Symbol	Condition	Rating			Unit
			Min	Typ	Max	
ZSCK pulsewidth	$t_{SCOW}$	15 pF load		1/96fs		
ZSCK pulse cycle	$t_{SCOY}$	15 pF load		1/48fs		
ZSRDATA and ZLRCK output delay time	$t_{DHL}$	15 pF load	0		60	ns
	$t_{DLH}$	15 pF load	0		60	ns

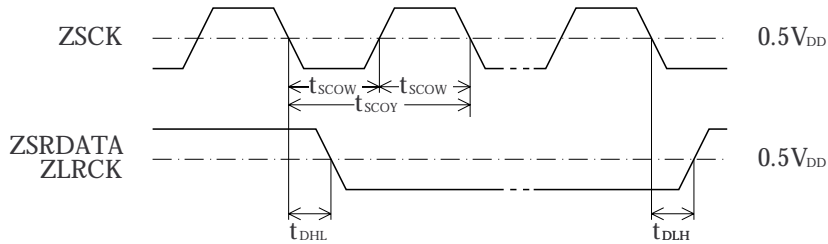

## DRAM access timing (NRAS, NCAS, NOE, NWE, A0 to A9, D0 to D3)

Parameter		Symbol	Condition	Rating			Unit
				Min	Typ	Max	
NRAS pulsewidth		$t_{RASL}$	15 pF load		5		$t_{CY}(\text{note})$
		$t_{RASH}$	15 pF load	3			$t_{CY}$
NRAS falling edge to NCAS falling edge		$t_{RCD}$	15 pF load		2		$t_{CY}$
NCAS pulsewidth		$t_{CASH}$	15 pF load	5			$t_{CY}$
		$t_{CASL}$	15 pF load		3		$t_{CY}$
NRAS falling edge to address	Setup time	$t_{RADS}$	15 pF load		1		$t_{CY}$
	Hold time	$t_{RADH}$	15 pF load		1		$t_{CY}$
NCAS falling edge to address	Setup time	$t_{CADS}$	15 pF load		1		$t_{CY}$
	Hold time	$t_{CADH}$	15 pF load		5		$t_{CY}$
NCAS falling edge to data write	Setup time	$t_{CWDS}$	15 pF load		3		$t_{CY}$
	Hold time	$t_{CWDH}$	15 pF load		3		$t_{CY}$
NCAS rising edge to data read	Input setup	$t_{CRDS}$		40			ns
	Input hold	$t_{CRDH}$		0			ns
NOE pulsewidth		$t_{OEL}$	15 pF load		6		$t_{CY}$
NWE pulsewidth		$t_{WEL}$	15 pF load		6		$t_{CY}$
NWE falling edge to NCAS falling edge		$t_{WCS}$	15 pF load		3		$t_{CY}$
Refresh cycle ( $f_s = 44.1$ kHz playback)  Memory system ON Decode sequence operation (RDEN=H)		$t_{REF}$	1M DRAM	Non compression		1.4	ms
				6-bit compression		3.7	ms
				5-bit compression		4.4	ms
				4-bit compression		5.5	ms
			4M DRAM	Non compression		2.7	ms
				6-bit compression		7.3	ms
				5-bit compression		8.8	ms
				4-bit compression		10.9	ms

Note.  $t_{CY}$  is the system clock (CLK) input (384fs) cycle time.  $t_{CY} = 59$  ns when  $f_s = 44.1$  kHz

DRAM access timing (with single DRAM)

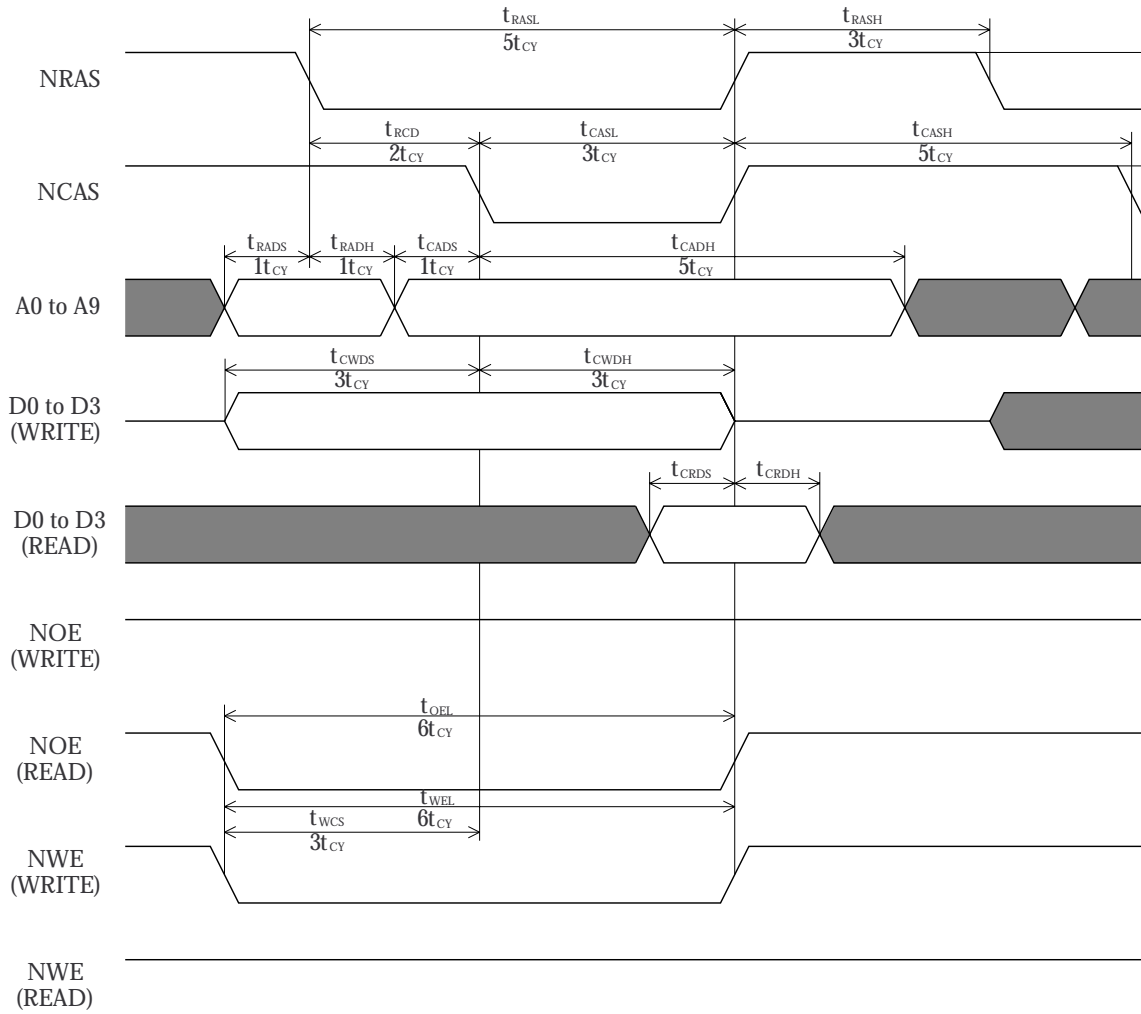

SM5859AF

DRAM access timing (with 2 DRAMs)

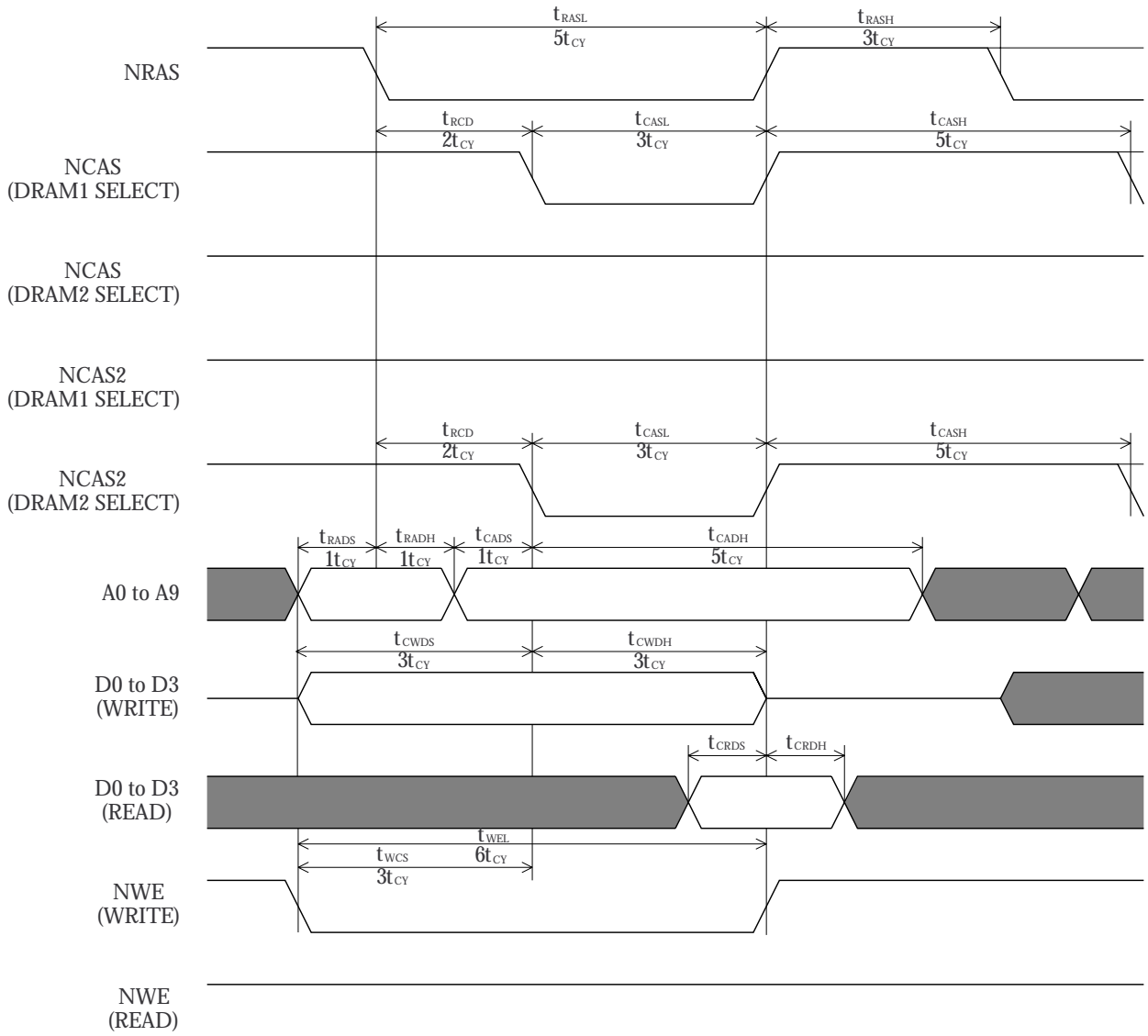

Block diagram

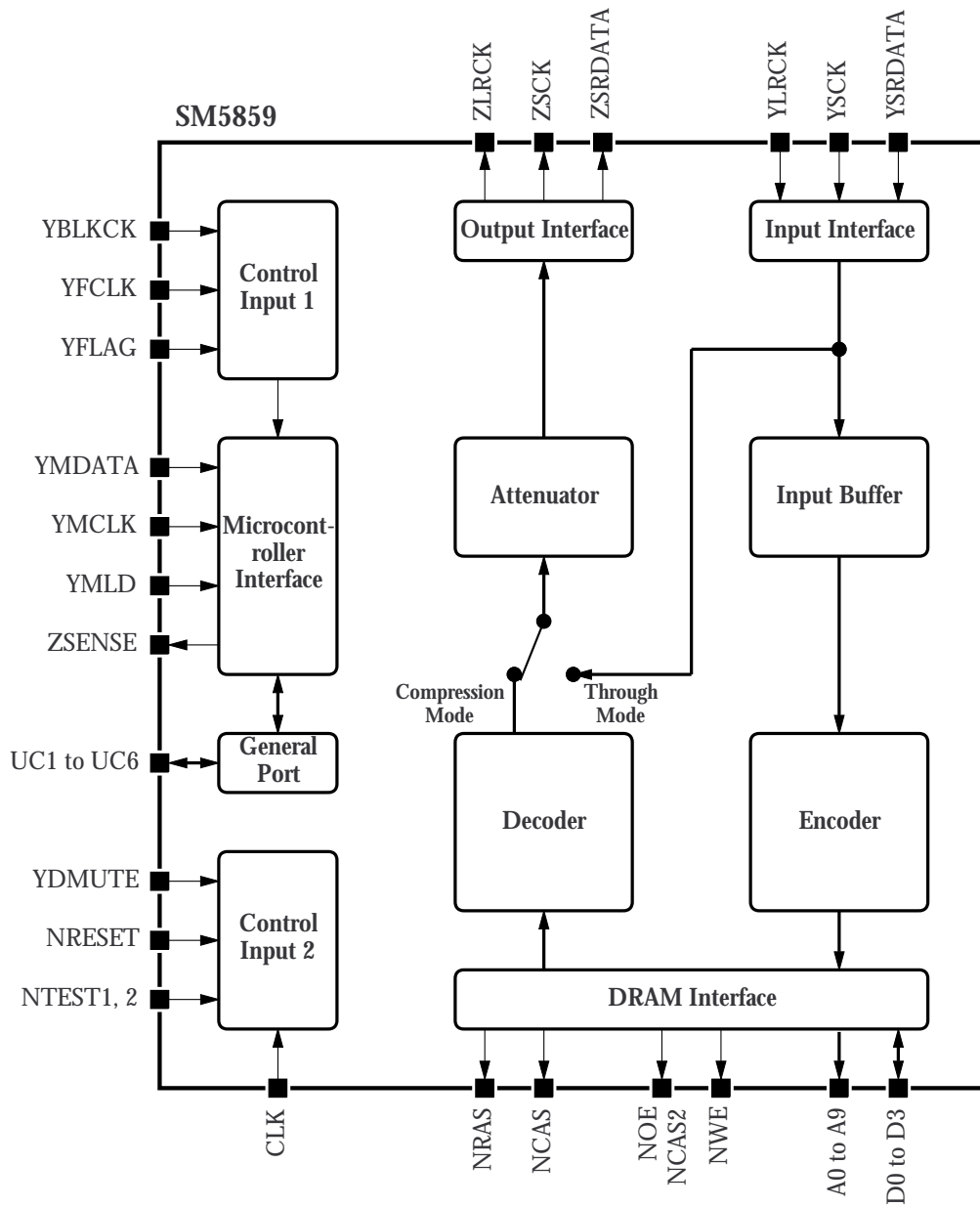

## Functional description

This IC has two modes of operation; shock-proof mode and through mode.

The operating sequences are controlled using commands from a microcontroller.

## Microcontroller interface

Commands from the microcontroller are input using 3 bit serial inputs; data (YMDATA), bit clock (YMCLK) and load signal (YMLD).

In the case of a read command from the microcontroller, bit serial data is output (ZSENSE) synchronized to the bit clock input (YMCLK).

### Write command format

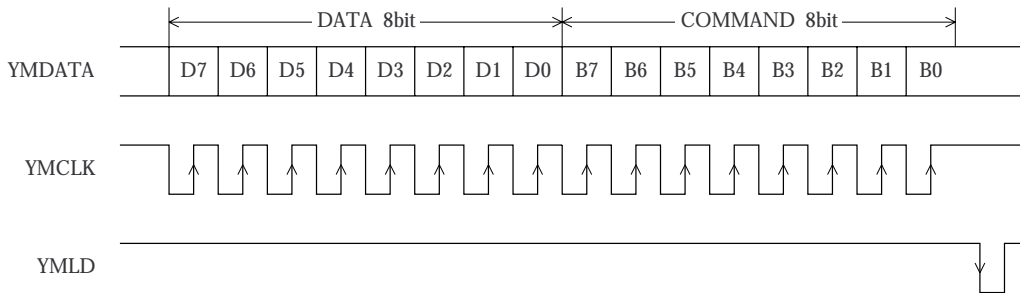

### Read command format (Commands 90, 91, 93)

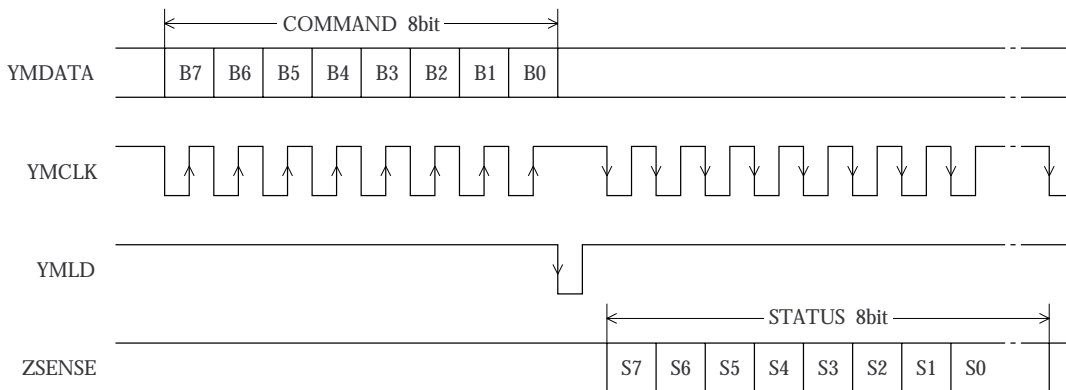

### Read command format (Command 92 (memory residual read))

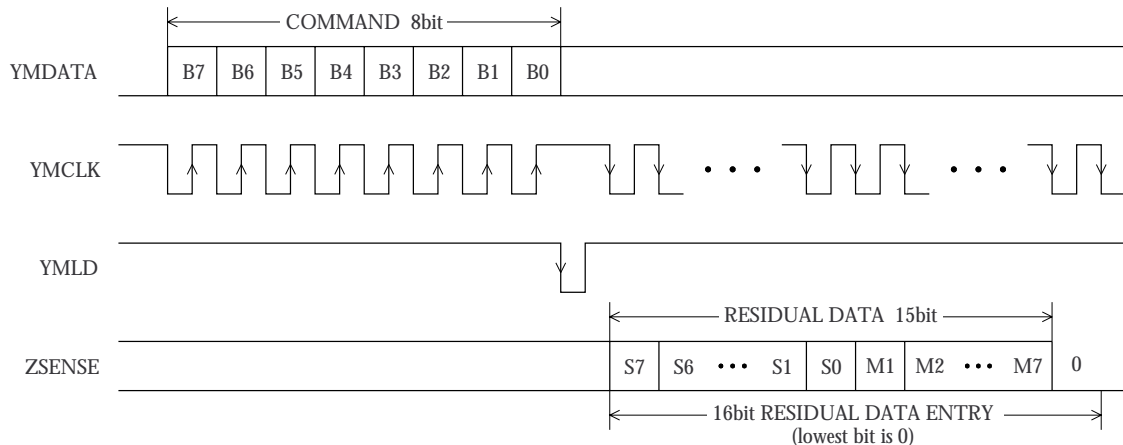

**Command table**

**Write command summary**

**MS command 80**

Anti-shock memory system settings

**80hex = 1000 0000** <sup>B7 B6 B5 B4 B3 B2 B1 B0</sup>

Bit	Name	Function	H operation	Reset level
D7	MSWREN	Encode sequence start/stop	Start	L
D6	MSWACL	Write address reset	Reset	L
D5	MSRDEN	Decode sequence start/stop	Start	L
D4	MSRACL	Read address reset	Reset	L
D3	MSDCN2	MSDCN2=H, MSDCN1=H: 3-pair comparison start MSDCN2=H, MSDCN1=L: 2-pair comparison start		L
D2	MSDCN1	MSDCN2=L, MSDCN1=H: Direct-connect start MSDCN2=L, MSDCN1=L: Connect operation stop		L
D1	WAQV	Q data valid	Valid	L
D0	MSON	Memory system ON	ON	L

**Extension I/O settings 81**

Extension I/O port input/output settings

**81hex = 1000 0001** <sup>B7 B6 B5 B4 B3 B2 B1 B0</sup>

Bit	Name	Function	H operation	Reset level
D7				
D6				
D5	UC6OE	Extension I/O port UC6 input/output setting	Output	L
D4	UC5OE	Extension I/O port UC5 input/output setting	Output	L
D3	UC4OE	Extension I/O port UC4 input/output setting	Output	L
D2	UC3OE	Extension I/O port UC3 input/output setting	Output	L
D1	UC2OE	Extension I/O port UC2 input/output setting	Output	L
D0	UC1OE	Extension I/O port UC1 input/output setting	Output	L

**Extension I/O output data settings 82**

Extension port HIGH/LOW output level

A port setting is invalid if that port has already been defined as an input using the 81H command above.

**82hex = 1000 0010** <sup>B7 B6 B5 B4 B3 B2 B1 B0</sup>

Bit	Name	Function	H operation	Reset level
D7				
D6				
D5	UC6WD	Extension I/O port UC6 output data setting	H output	L
D4	UC5WD	Extension I/O port UC5 output data setting	H output	L
D3	UC4WD	Extension I/O port UC4 output data setting	H output	L
D2	UC3WD	Extension I/O port UC3 output data setting	H output	L
D1	UC2WD	Extension I/O port UC2 output data setting	H output	L
D0	UC1WD	Extension I/O port UC1 output data setting	H output	L

# SM5859AF

## ATT, MUTE settings 83

**83hex = 1000 0011**  
B7 B6 B5 B4 B3 B2 B1 B0

Bit	Name	Function	H operation	Reset level
D7	ATT	Attenuator enable	Attenuator ON	L
D6	MUTE	Forced muting (changes instantaneously)	Mute ON	L
D5	SOFT	Soft muting (changes smoothly when ON only)	Soft mute	L
D4				
D3	CMP12	12-bit comparison connect/ 16-bit comparison connect	12-bit comparison	L
D2				
D1				
D0				

Refer to Attenuation, Soft mute, Force mute.

## Attenuation level settings 84

**84hex = 1000 0100**  
B7 B6 B5 B4 B3 B2 B1 B0

Bit	Name	Function	H operation	Reset level
D7	K7	MSB $2^{-1}$		L
D6	K6	$2^{-2}$		H
D5	K5	$2^{-3}$		L
D4	K4	$2^{-4}$		L
D3	K3	$2^{-5}$		L
D2	K2	$2^{-6}$		L
D1	K1	$2^{-7}$		L
D0	K0	LSB $2^{-8}$		L

Refer to Attenuation, Soft mute, Force mute

## Option settings 85

**85hex = 1000 0101**  
B7 B6 B5 B4 B3 B2 B1 B0

Bit	Name	Function	H operation	Reset level
D7	RAM4M	4M (1M×4 bits)/1M (256K×4 bits) DRAM type setting	4M	L
D6	RAMX2	Number of DRAMs setting (2 or 1)	2	L
D5	YFLGS	FLAG6 set conditions (reset using status read command 90H) - When YFLGS=0, YFCKP=0, YFCLK input falling edge, YFLAG=L - When YFLGS=0, YFCKP=1, YFCLK input rising edge, YFLAG=L		L
D4	YFCKP	- When YFLGS=1, YFCKP=0, YFLAG=L - When YFLGS=1, YFCKP=1, YFLAG=H		L
D3	COMPFB	Full-bit non compression mode		L
D2	COMP6B	6-bit compression mode		H
D1	COMP5B	5-bit compression mode		L
D0	COMP4B	4-bit compression mode		L

When the number of compression bits is set incorrectly (2 or more bits in D0 to D3 are set to 1 or all bits are set to 0),  
 6-bit compression mode is selected.

Read command summary

Anti-shock memory status (1) 90

90hex = <sup>B7</sup>1001 <sup>B6</sup><sup>B5</sup>0000 <sup>B4</sup><sup>B3</sup><sup>B2</sup><sup>B1</sup><sup>B0</sup>

Bit	Name	Function	HIGH-level state
S7	FLAG6	Signal processor IC jitter margin exceeded	Exceeded
S6	MSOVF	Write overflow (Read once only when RA exceeds WA)	DRAM overflow
S5			
S4			
S3	DCOMP	Data compare-connect sequence operating	Compare-connect sequence operating
S2	MSWIH	Encode sequence stop due to internal factors	Encoding stopped
S1	MSRIH	Decode sequence stop due to internal factors	Decoding stopped
S0			

Refer to Status flag operation summary

Anti-shock memory status (2) 91

91hex = <sup>B7</sup>1001 <sup>B6</sup><sup>B5</sup>0001 <sup>B4</sup><sup>B3</sup><sup>B2</sup><sup>B1</sup><sup>B0</sup>

Bit	Name	Function	HIGH-level state
S7	MSEMP	Valid data empty state (Always HIGH when RA exceeds VWA)	No valid data
S6	OVFL	Write overflow state (Always HIGH when WA exceeds RA)	Memory full
S5	ENCOD	Encode sequence operating state	Encoding
S4	DECOD	Decode sequence operating state	Decoding
S3			
S2			
S1			
S0			

Refer to Status flag operation summary.

# SM5859AF

## Anti-shock memory valid data residual 92

92hex = <sup>B7</sup>1001 <sup>B6</sup><sup>B5</sup>00 <sup>B4</sup>00 <sup>B3</sup>00 <sup>B2</sup>00 <sup>B1</sup>00 <sup>B0</sup>00

Bit	Name	Function	
S7	AM20	Valid data accumulated VWA-RA (MSB) 4M bits	
S6	AM19	2M bits	
S5	AM18	1M bits	
S4	AM17	512K bits	
S3	AM16	256K bits	
S2	AM15	128K bits	
S1	AM14	64K bits	
S0	AM13	32K bits	
M1	AM12	16K bits	
M2	AM11	8K bits	
M3	AM10	4K bits	
M4	AM09	2K bits	
M5	AM08	1K bits	
M6	AM07	512 bits	
M7	AM06	256 bits	
M8	AM05 to	128 to 4 bits	0 constant output
...	AM00		

Note. The time conversion factor varies depending on the compression bit mode. (M = 1,048,576 K= 1,024)  
 Residual time (sec) = Valid data residual (Mbits) × Time conversion value k  
 where the Time conversion value k (sec/Mbit) = 2.78(4 bits), 2.22 (5 bits), 1.85 (6 bits) and 0.74 (Full bits).

## Extension I/O inputs 93

Input data entering (or output data) an extension port terminal is echoed to the microcontroller.  
 (That is, the input data entering an I/O port configured as an input port using the 81H command,  
 OR the output data from a pin configured as an output port using the 82H command.)

93hex = <sup>B7</sup>1001 <sup>B6</sup>00 <sup>B5</sup>00 <sup>B4</sup>00 <sup>B3</sup>00 <sup>B2</sup>00 <sup>B1</sup>00 <sup>B0</sup>00

Bit	Name	Function	HIGH-level state
S7			
S6			
S5	UC6RD		
S4	UC5RD		
S3	UC4RD		
S2	UC3RD		
S1	UC2RD		
S0	UC1RD		

## SM5859AF

### Status flag operation summary

Flag name	Read method		
FLAG6	READ 90H bit 7	Meaning	- Indicates to the CD signal processor DSP (used for error correction, de-interleaving) that a disturbance has exceeded the RAM jitter margin.
		Set	- Set according to the YFLAG input and the operating state of YFCKP and YFLGS. FLAG6 set conditions When YFLGS=0, YFCKP=0, YFCLK input falling edge, YFLAG=L When YFLGS=0, YFCKP=1, YFCLK input rising edge, YFLAG=L When YFLGS=1, YFCKP=0, YFLAG=L When YFLGS=1, YFCKP=1, YFLAG=H
		Reset	- By 90H status read - By 80H command when MSON=ON - After external reset
MSOVF	READ 90H bit 6	Meaning	- Indicates once only that a write to external DRAM has caused an overflow. (When reset by the 90H status read command, this flag is reset even if the overflow condition continues.)
		Set	- When the write address (WA) exceeds the read address (RA)
		Reset	- By 90H status read - When a read address clear (MSRACL) or write address clear (MSWACL) command is issued - After external reset
DCOMP	READ 90H bit 3	Meaning	- Indicates that a compare-connect sequence is operating
		Set	- When a (3-pair or 2-pair) compare-connect start command is received (MSDCN2=1) - When a direct connect command is received (MSDCN2=0, MSDCN1=1)
		Reset	- When a (3-pair or 2-pair) comparison detects conforming data - When the connect has been performed after receiving a direct connect command - When a compare-connect stop command (MSDCN2=0, MSDCN1=0) is received - When a MSWREN=1 command is received (However, if a compare-connect command is received at the same time, the compare-connect command has priority.) - After external reset
MSWIH	READ 90H bit 2	Meaning	- Indicates that the encode sequence has stopped due to internal factors (not microcontroller commands)
		Set	- When FLAG6 (above) is set - When MSOVF (above) is set
		Reset	- When conforming data is detected after receiving a compare-connect start command - When the connect has been performed after receiving a direct connect command - When a read address clear (MSRACL) or write address clear (MSWACL) command is received - After external reset
MSRIH	READ 90H bit 1	Meaning	- Indicates that the decode sequence has stopped due to internal factors (not microcontroller commands)
		Set	- When the valid data residual becomes 0
		Reset	- By 90H status read - When a read address clear (MSRACL) or write address clear (MSWACL) command is issued - After external reset

SM5859AF

Flag name	Read method		
MSEMP	READ 91H bit 7	Meaning	- Indicates that the valid data residual has become 0
		Set	- When the VWA (final valid data's next address) = RA (address from which the next read would take place)
		Reset	- Whenever the above does not apply
OVFL	READ 91H bit 6	Meaning	- Indicates a write to external DRAM overflow state
		Set	- When the write address (WA) exceeds the read address (RA). (Note: This flag is not set when WA=RA through an address initialize or reset operation.)
		Reset	- When the read address (RA) is advanced by the decode sequence - When a read address clear (MSRACL) or write address clear (MSWACL) command is issued - After external reset
ENCOD	READ 91H bit 5	Meaning	- Indicates that the encode sequence (input data entry, encoding, DRAM write) is operating
		Set	- By the 80H command when MSWREN=1 - When conforming data is detected during compare-connect operation - When the connect has been performed after receiving a direct connect command
		Reset	- When the FLAG6 flag=1 (above) - When the OVFL flag=1 (above) - By the 80H command when MSWREN=0 - By the 80H command when MSDCN1=1 or MSDCN2=1 (compare-connect start command) - By the 80H command when MSON=0 - After external reset  Note. Reset conditions have priority over set conditions. For example, if the 80H command has MSWREN=1 and MSDCN1=1, the ENCOD flag is reset and compare-connect operation starts.
DECOD	READ 91H bit 4	Meaning	- Indicates that the decode sequence (read from DRAM, decoding, attenuation, data output) is operating
		Set	- By a new 80H command when MSRDN=1 and the MSEMP flag=0 (above)
		Reset	- Whenever the above does not apply

---

**Write command supplementary information**
**80H (MS command)****- MSWREN**

When 1: Encode sequence starts

Invalid when MSON is not 1 within the same 80H command

Invalid when FLAG6=1

Invalid when OVFL=1

Invalid when a compare-connect start command (MSDCN2=1 or MSDCN1=1) occurs simultaneously

Direct connect if a compare-connect sequence is already operating

When 0: Encode sequence stops

**- MSWACL**

When 1: Initializes the write address (WA)

When 0: No operation

**- MSRDEN**

When 1: Decode sequence starts

Does not perform decode sequence if MSON=1. If there is no valid data, decode sequence temporarily stops. But, because the MSRDEN flag setting is maintained as is, the sequence automatically re-starts when valid data appears.

When 0: Decode sequence stops

**-MSRACL**

When 1: Initializes the read address (RA)

When 0: No operation

**- MSDCN2, MSDCN1**

When 1 and 1: 3-pair compare-connect sequence starts

When 1 and 0: 2-pair compare-connect sequence starts

When 0 and 1: Direct connect sequence starts

When 0 and 0: Compare-connect sequence stops. No operation if a compare-connect sequence is not operating.

**- WAQV**

When 1: The immediately preceding YBLKCK falling-edge timing WA (write address) becomes the VWA (valid write address).

When 0: No operation

**- MSON**

When 1: Memory system turns ON and compression-type shock-proof operation starts

When 0: Memory system turns OFF and through-mode playback starts. (In this mode, the attenuator is still active.)

**81H (I/O setting on extension I/O)****82H (Setting output data on extension I/O)**

**83H (ATT, MUTE settings)**

- ATT (attenuator enable)

When 1: Attenuator settings become active (84H command)

When 0: Attenuator settings become inactive, and output continues without attenuation

- MUTE (forced muting)

When 1: Outputs are instantaneously muted to 0.(note 1)

Same effect as taking the YDMUTE pin HIGH.

When 0: No muting(note 1)

(note1) Effective at the start of a Left-channel output data.

- SOFT (soft muting)

When 1: Outputs are smoothly muted to 0.

When 0: No muting.

Soft mute release occurs instantaneously to either the value set by the 84H command (When ATT=1) or 0dB (When ATT=0)

- MUTE, SOFT, YDMUTE relationship

When all mute inputs are 0, mute is released.

- CMP12 (12-bit comparison connection)

When 1: Performs comparison connection using only the most significant 12 bits of input data.

When 0: Performs comparison connection using all 16 bits of input data.

**85H (option settings)**

- RAM4M

When 1: Uses 4M DRAMs (1M×4 bits)

When 0; Uses 1M DRAMs (256K×4 bits)

- RAMX2

When 1: Uses 2 DRAMs

When 0: Uses a single DRAM

- YFLGS, YFCKP see 9-2-3.

When 0 and 0: Sets FLAG6 on the falling edge of YFCLK when YFLAG=0

When 0 and 1: Sets FLAG6 on the rising edge of YFCLK when YFLAG=0

When 1 and 0: Sets FLAG6 when YFLAG=0

When 1 and 1: Sets FLAG6 when YFLAG=1

- COMPFB, COMP6B, COMP5B, COMP4B

When 0, 0, 0 and 1: Selects 4-bit compression mode

When 0, 0, 1 and 0: Selects 5-bit compression mode

When 1, 0, 0 and 0: Selects full-bit compression mode

In all other cases: Selects 6-bit compression mode  
Changing mode without initialize in operation is possible.

## Shock-proof operation overview

Shock-proof mode is the mode that realizes shock-proof operation using external DRAM. Shock-proof mode is invoked by setting MSON=H in microcon-

troller command 80H.

This mode comprises the following 3 sequences.

### - Encode sequence

1. Input data from a signal processor IC is stored in internal buffers.
2. Encoder starts after a fixed number of data have been received.

3. The encoder, after the most suitable predicting filter type and quantization steps have been determined, performs APC encoding and then writes to external DRAM.

### - Decode sequence

1. Reads compressed data stored in external buffer RAM at rate  $f_s$ .
2. Decoder starts, using the predicting filter type and quantization levels used when encoded.

3. Performs attenuation operation (including muting operation)

4. Outputs the result.

### - Compare-connect sequence

1. Encoding immediately stops when either external buffer RAM overflows or when a CD read error occurs due to shock vibrations.
2. Then, using microcontroller command 80H, the compare-connect start command is executed and compare-connect sequence starts.

3. Compares data re-read from the CD with the processed final valid data stored in RAM (confirms its correctness).

4. As soon as the comparison detects conforming data, compare-connect sequence stops and encode sequence re-starts, connecting the data directly behind previous valid data.

**RAM addresses**

The SM5859 uses either 1 or 2 external 1M or 4M DRAMs as external buffers.

Three kinds of addresses are used for external RAM control.

WA (write address)

RA (read address)

VWA (valid write address)

Among these, VWA is the write address for conforming data whose validity has been confirmed. Determination of the correctness of data read from the CD is delayed relative to the encode write processing, so VWA is always delayed relative to WA.

The region available for valid data is the area between VWA-RA.

**- Connect data work area**

This is an area of memory reserved for connect data. This area is 2Kbits if using 1M DRAMs, or 4Kbits if using 4M DRAMs.

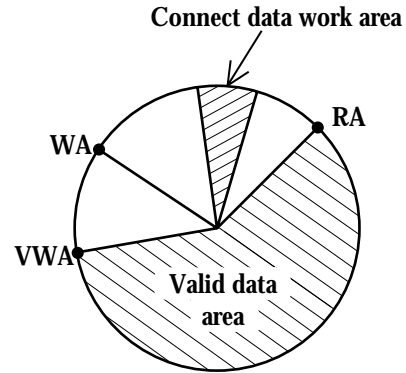

Fig1. RAM addresses

**VWA (valid write address)**

The VWA is determined according to the YBLKCK pin and WAQV command. Refer to the timing chart below.

1.YBLKCK is a 75 Hz clock(HIGH) when used for normal read mode and it is a 150Hz clock when used for double-speed read mode. Both modes clock are synchronized to the CD format block end timing.

When this clock goes LOW, WA which is the write address of internal encode sequence, is stored (see note 2).

2.The microcontroller checks the subcode and, if confirmed to be correct, generates a WAQV command (80H).

3.When the WAQV command is received, VWA is updated according to the previously latched WA.

(note 2) Actually, there is a small time difference, or gap, between the input data and YBLKCK. This gap serves to preserves the preceding WA to protect against incorrect operation.

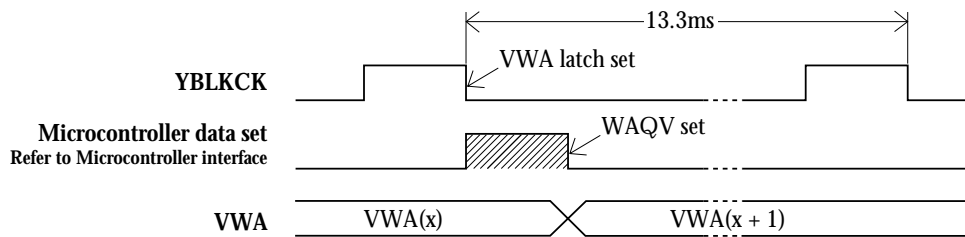

Values shown are for rate fs. The values are 1/2 those shown at rate 2fs.

Fig 2. YBLKCK and VWA relationship

**YFLAG, YFCLK, FLAG6**

Correct data demodulation becomes impossible for the CD signal processor IC when a disturbance exceeding the RAM jitter margin occurs. The YFLAG signal input pin is used to indicate when such a condition has occurred.

The YFCLK signal is a 7.35 kHz clock synchronized to the CD format frame 1.

The IC checks the YFLAG input and stops the

encode sequence when such a disturbance has occurred, and then makes FLAG6 active.

The YFLAG check method used changes depending on the YFLGS flag and YFCKP flag (85H command). See table1.

If YFLGS is set to 1, then YFCLK should be tied either High or Low.

85H command			FLAG6 set conditions	FLAG6 reset conditions
	YFLGS	YFCKP		
1	0	0	When YFLAG=LOW on YFCLK input falling edge	- By status read (90H command) - When MSON=LOW - After system reset
2		1	When YFLAG=LOW on YFCLK input rising edge	
3	1	0	When YFLAG=LOW	
4		1	When YFLAG=HIGH	

Table1. YFLAG signal check method

**Compare-connect sequence**

The SM5859 supports three kinds of connect modes; 3-pair compare-connect, 2-pair compare-connect and direct connect.

Note that the SM5859 can also operate in 12-bit comparison connect mode using only the most significant 12 bits of data for connection operation.

In 3-pair compare-connect mode, the final 6 valid data (3 pairs of left- and right-channel data input before encode processing) and the most recently input data are compared until three continuous data pairs all conform. At this point, the encode sequence is re-started and data is written to VWA.

In 2-pair compare-connect mode, comparison occurs just as for 3-pair comparison except that only 2 pairs from the three compared need to conform with the valid data. At this point, the encode sequence is re-started and data is written to VWA.

In direct-connect mode, comparison is not performed at all, and encode sequence starts and data is written to the VWA. This mode is for systems that cannot perform compare-connect operation.

**- Compare-connect preparation time****1. Comparison data preparation time**

Internally, when the compare-connect start command is issued, a sequence starts to restore the data for comparison. The time required for this preparation after receiving the command is approximately  $2.5 \times (1/f_s)$ . (approximately 60  $\mu$ s when  $f_s = 44.1$  kHz)

2. After the above preparation is finished, data is input beginning from the left-channel data and comparison starts.

3. If the compare-connect command is issued again, the preparation time above is not necessary and operation starts from step 2.

4. The same sequence takes place in direct-connect mode also. However, at the point when 3 words have been input, all data is directly connected as if comparison and conformance had taken place.

**- Compare-connect sequence stop**

If a compare-connect stop command (80H with MSDCN1= 1, MSDCN2= 0) is input from the micro-controller, compare-connect sequence stops.

If compare-connect sequence was not operating, the compare-connect stop command performs no operation. However, make sure that the other bit settings within the same 80H command are valid.

## Encode sequence temporary stop

- When RAM becomes full, MSWREN is set LOW using the 80H command and encode sequence stops. (For details of the stop conditions, refer to the description of the ENCOD flag.)

- Then, if MSWREN is set HIGH without issuing a compare-connect start command, the encode sequence re-starts. At this time, newly input data is written not to VWA, but to WA. In this way, the data already written to the region between VWA and WA is not lost.

- But if the MSWREN is set HIGH (80H command) after using the compare-connect start command even only once, data is written to VWA. If data is input before comparison and conformance is detected, the same operation as direct-connect mode takes place when the command is issued. After comparison and conformance are detected, no operation is performed because the encode sequence has already been started. However, make sure that the other bit settings within the same 80H command are valid.

## DRAM refresh

- DRAM initialization refresh

A 15-cycle RAS-only refresh is carried out for DRAM initialization under the following condition.

When MSON changes from 0 to 1 in command 80H.

When from MSON=1, MSR DEN=0 and MSWREN=0 states only MSWREN changes to 1. In this case, encode sequence immediately starts and initial data is written (at 2fs rate input) after a delay of 0.7ms.

- Refresh during Shock-proof mode operation

In this IC, a data access operation to any address also serves as a data refresh. Accordingly, there are no specific refresh cycles other than the initialization refresh cycle (described above).

This has the resulting effect of saving on DRAM power dissipation.

A data access to DRAM can occur in an encode sequence write operation or in a decode sequence read operation. In an encode sequence write operation the connect operation is stopped, while in a decode sequence read operation the data is always output to the D/A converter in a fixed manner. The refresh rate for each DRAM during decode sequence is shown in the table below.

The decode sequence, set by MSON=1 and MSR DEN=1, operates when valid data is in DRAM (when MSEMP=0).

- When MSON=0 or both ENCOD and DECOD=0 (both encode sequence and decode sequence are stopped), DRAM is not refreshed because no data is being accessed.

Data compression mode	DRAMs used (same for 1 or 2 DRAMs)	
	1M (256K×4 bits)	4M (1M×4 bits)
4 bit	5.44 ms	10.88 ms
5 bit	4.35 ms	8.71 ms
6 bit	3.63 ms	7.26 ms
Full bit	1.36 ms	2.72 ms

Table 2. Decode sequence refresh rate

### Selecting compression mode

Even when the compression mode is selected with the 85H command during shock-proof operation, no malfunction occurs.

immediately after input of the 85H command, but it is performed at the following timing.

The compression mode change is not performed

After changing the mode, zero data of one block is output.

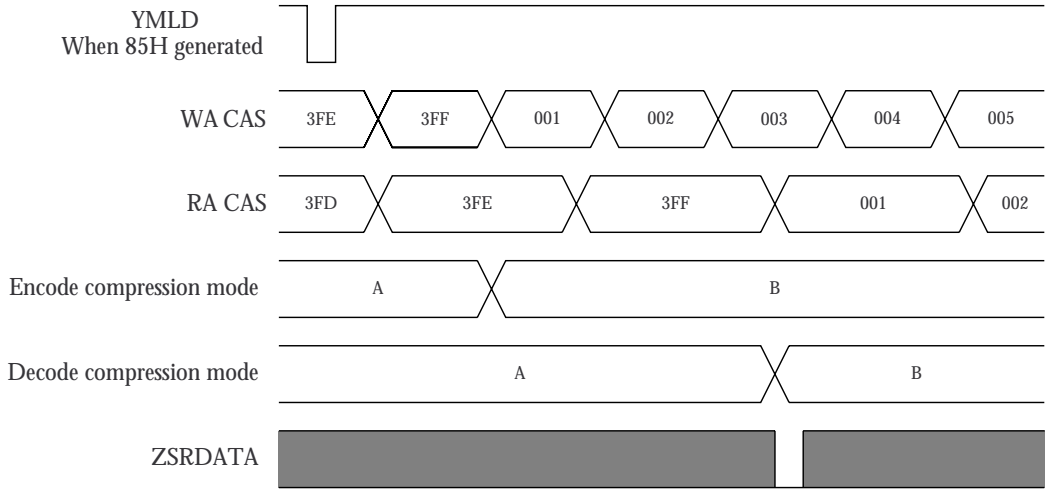

(note) CAS-000 is connect data.

## Through-mode operation

If MSON is set LOW (80H command), an operating mode that does not perform shock-proof functions becomes active. In this case, input data is passed as-is (after attenuator and mute operations) to the output. External DRAM is not accessed.

- In this case, input data needs to be at a rate  $f_s$  and the input word clock must be synchronized to the CLK input (384 $f_s$ ). However, short range jitter can be tolerated (jitter-free system).

- Jitter-free system timing starts from the first YLRCK rising edge after either (A) a reset (NESET= 0) release by taking the reset input from LOW to HIGH or (B) by taking MSON from HIGH to

LOW. Accordingly, to provide for the largest possible jitter margin, it is necessary that the YLRCK clock be at rate  $f_s$  by the time jitter-free timing starts.

The jitter margin is  $0.2/f_s$ .

This jitter margin is the allowable difference between the system clock (CLK)  $1/384$  divided,  $f_s$  rate clock and the YLRCK input clock.

If the timing difference exceeds the jitter margin, irregular operation like data being output twice or conversely complete "1" data output may occur. In the worst case, a click noise will also be generated.

## Attenuation

- The attenuation register is set by the 84H command.

- The attenuation register set value becomes active when the 83H command sets the ATT flag to 1.

When the ATT flag is 0, the attenuation register value is considered to be the equivalent of 256 for a maximum gain of 0 dB.

- The gain (dB) is given from the set value (Datt) by the following equation.

Gain =  $20 \times \log(Datt/256)$  [dB]; left and right channels

- For the maximum attenuation register set value (Datt = 255), the corresponding gain is -0.03 dB. But when the ATT flag is 0 (Datt = 256), there is no attenuation.

- After a system reset initialization, the attenuation register is set to 64 (-12 dB). However, because the ATT flag is reset to 0, there is no attenuation.

- When the attenuation register setting changes or when the ATT flag changes, the gain changes smoothly from the previous set gain towards the new set value. If a new value for the attenuation level is set before the previously set level is reached, the gain changes smoothly towards the latest setting.

The gain changes at a rate of  $4 \times (1/f_s)$  per step. A full-scale change (255 steps) takes approximately 23.3 ms (when  $f_s = 44.1$  kHz). See fig 3.

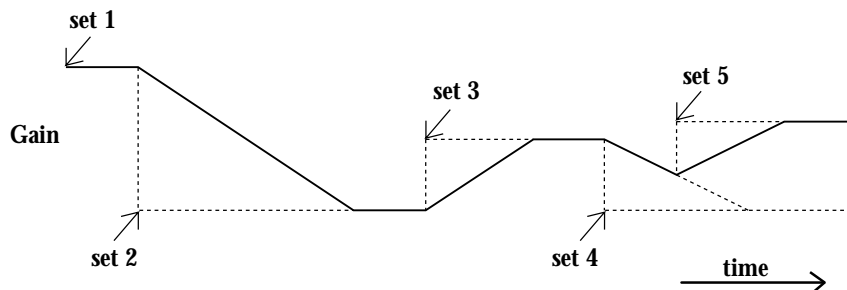

Fig 3 Attenuation operation example

## Soft mute

Soft mute operation is controlled by the SOFT flag using a built-in attenuation counter.

Mute is ON when the SOFT flag is 1. When ON, the attenuation counter output decrement by 1 step at a time, thereby reducing the gain. Complete mute takes  $1024/f_s$  (or approximately 23.2 ms for  $f_s = 44.1$  kHz).

Conversely, mute is released when the SOFT flag is 0. In this case, the attenuation counter instantaneously increases. The attenuation register takes on the value when the ATT flag was 1. If the ATT flag was 0, the new set value is 256 (0 dB).

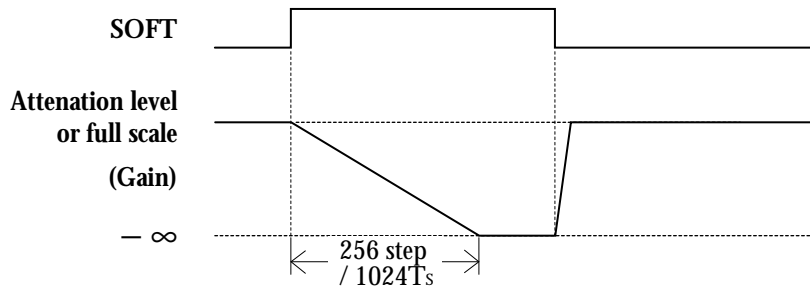

Fig 4. Soft mute operation example

## Force mute

Serial output data is muted by setting the YDMUTE pin input HIGH or by setting the MUTE flag to 1. Mute starts and finishes on the leading left-channel bit.

When MSON is HIGH and valid data is empty (MSEMP=H), the output is automatically forced into the mute state.

## 12-bit comparison connection

When the CMP12 flag is set to 1, the least significant 4 bits of the 16-bit comparison connection input data are discarded and comparison connection is performed using the remaining 12 bits.

Note that if the CMP12 flag is set to 1 during a comparison connection operation, only the most significant 12 bits are used for comparison connection from that point on.

## Timing charts

### Input timing (YSCK, YSRDATA, YLRCK)

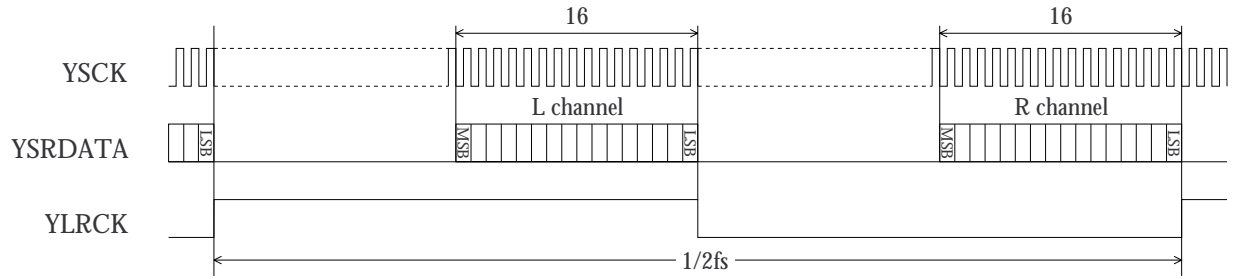

### Output timing (ZSCK, ZSRDATA, ZLRCK)

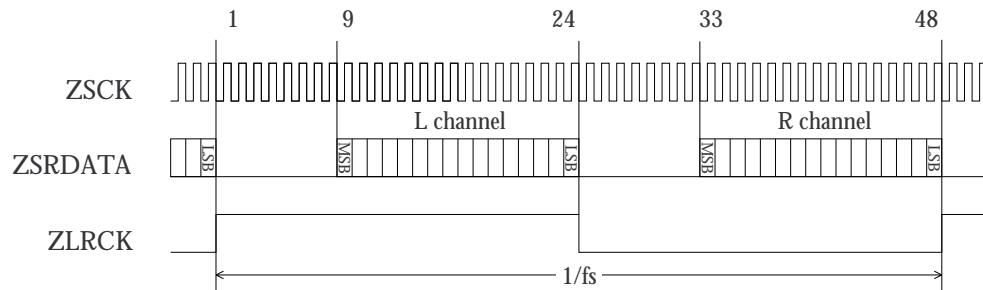

**DRAM write timing (NRAS, NCAS, NOE, NWE, A0 to A9, D0 to D3)**

**Write timing (with single DRAM)**

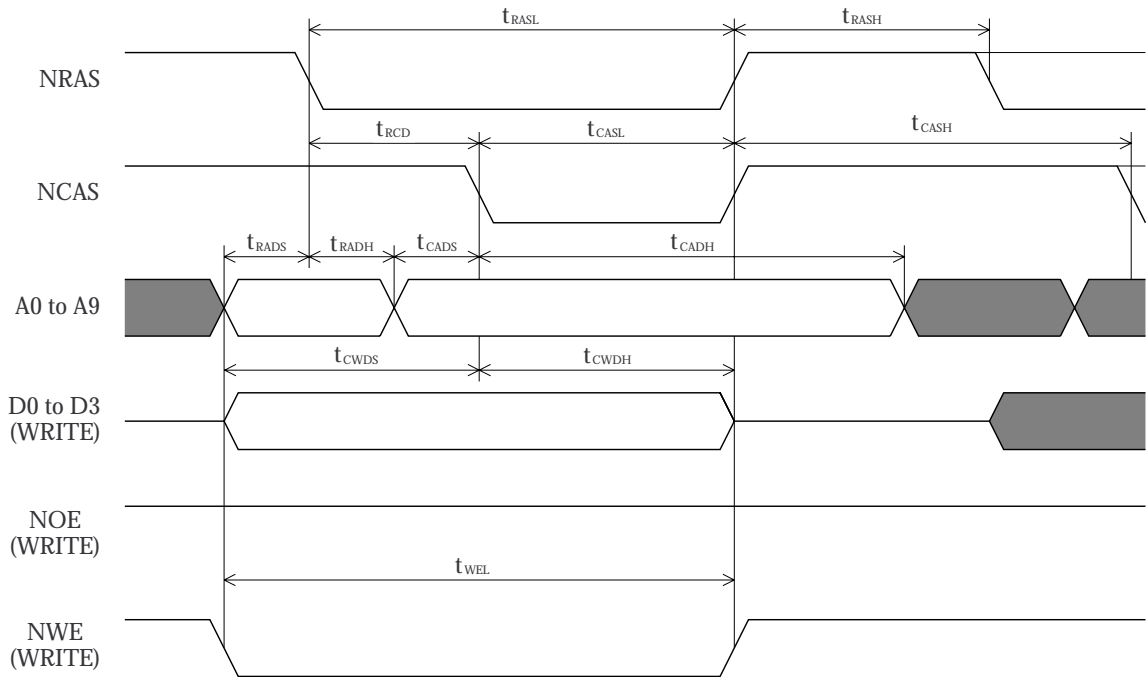

**Write timing (with 2 DRAMs)**

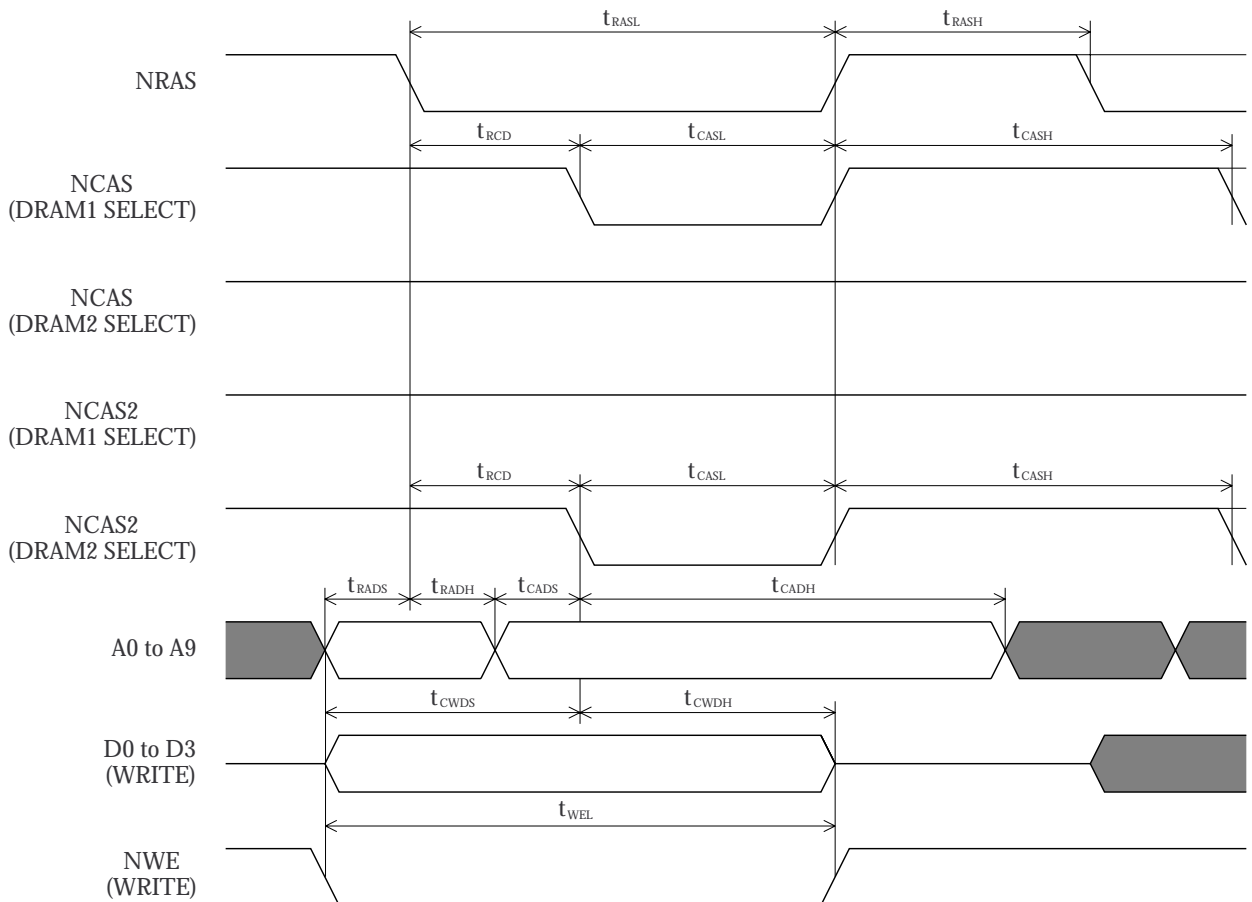

**DRAM read timing (NRAS, NCAS, NOE, NWE, A0 to A9, D0 to D3)**

**Read timing (with single DRAM)**

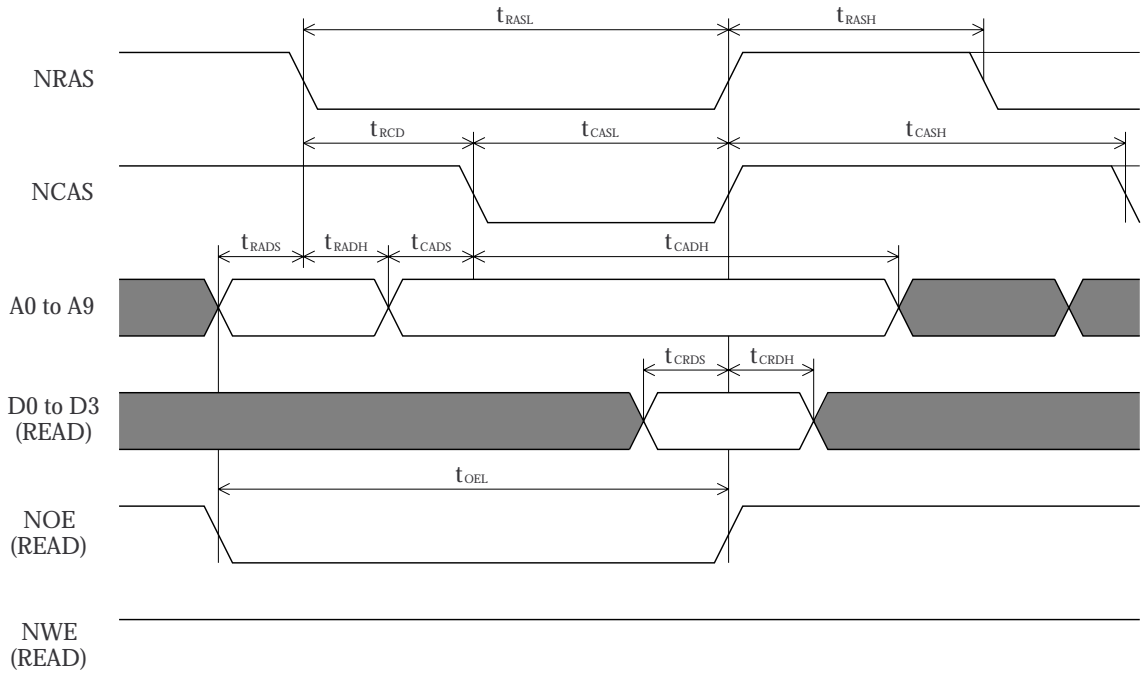

**Read timing (with 2 DRAMs)**

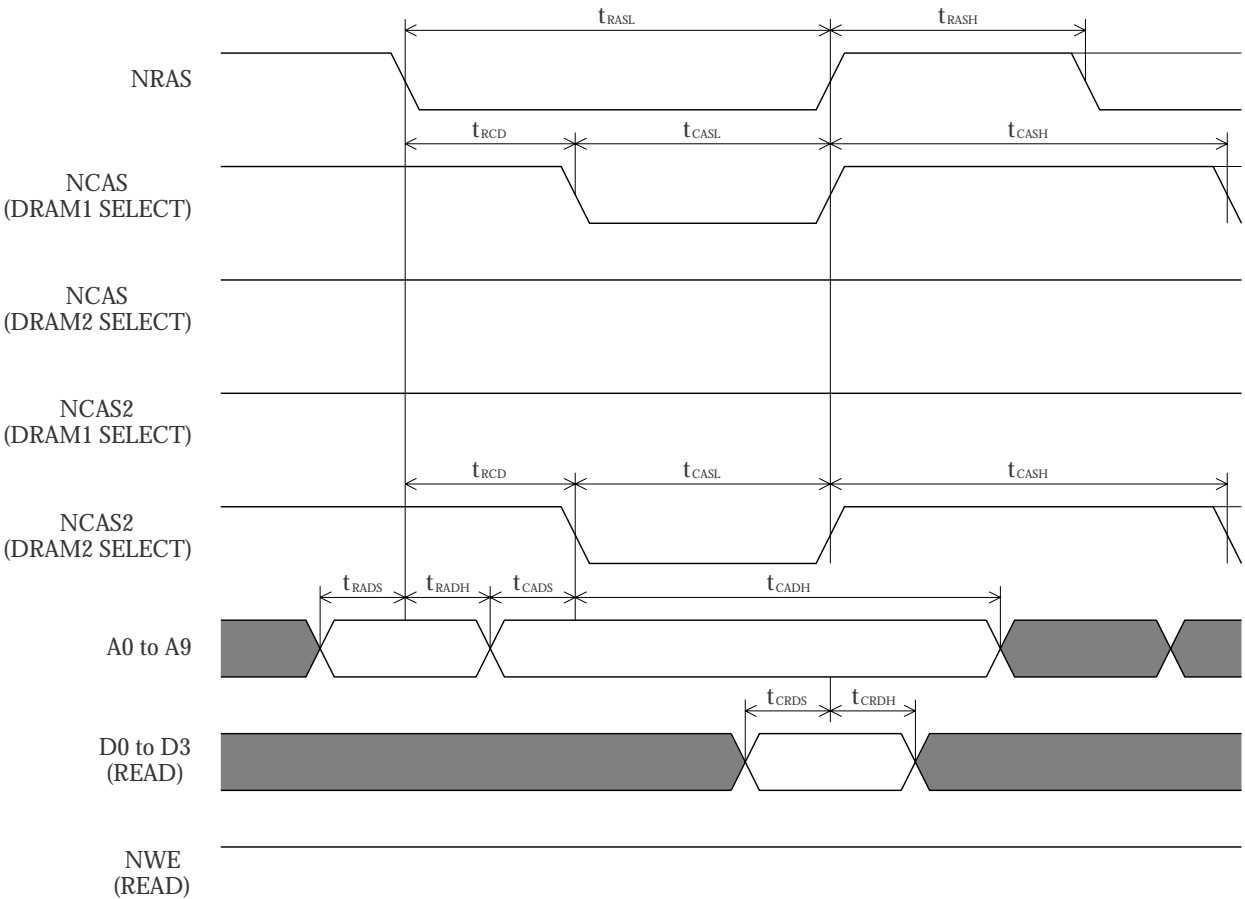

Connection example

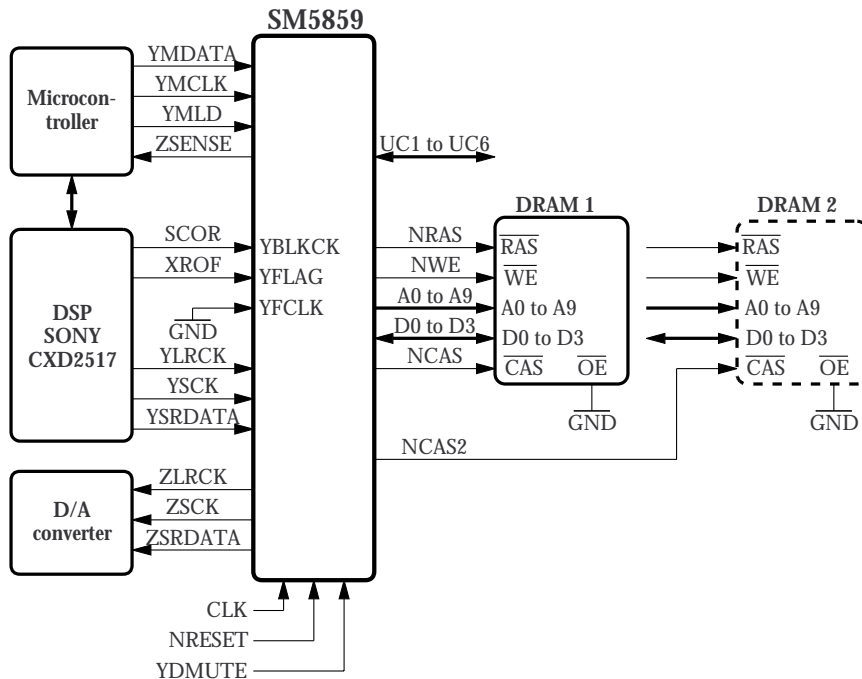
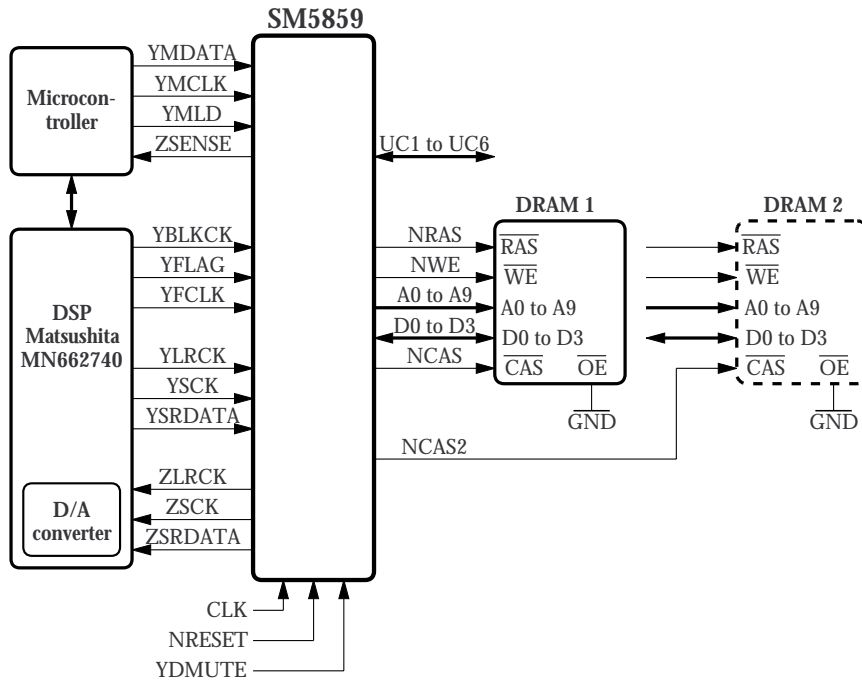

note1

- When 2 DRAMs are used, the DRAM  $\overline{OE}$  pins should be tied LOW.
- When single DRAM is used, the DRAM  $\overline{OE}$  pin should be tied LOW or controlled by the SM5859 NOE signal.

note 2 When CXD 2517 (Sony) is used

Set 85H of microcontroller command (option setting) as setting YFLAG take in;

D5: YFLAGS= 1

D4: YFCKP= 0

NIPPON PRECISION CIRCUITS INC. reserves the right to make changes to the products described in this data sheet in order to improve the design or performance and to supply the best possible products. Nippon Precision Circuits Inc. assumes no responsibility for the use of any circuits shown in this data sheet, conveys no license under any patent or other rights, and makes no claim that the circuits are free from patent infringement. Applications for any devices shown in this data sheet are for illustration only and Nippon Precision Circuits Inc. makes no claim or warranty that such applications will be suitable for the use specified without further testing or modification. The products described in this data sheet are not intended to use for the apparatus which influence human lives due to the failure or malfunction of the products. Customers are requested to comply with applicable laws and regulations in effect now and hereinafter, including compliance with export controls on the distribution or dissemination of the products. Customers shall not export, directly or indirectly, any products without first obtaining required licenses and approvals from appropriate government agencies.



NIPPON PRECISION CIRCUITS INC.

4-3, 2-chome Fukuzumi, Koto-ku  
Tokyo, 135 -8430, JAPAN  
Telephon: 03-3642-6661  
Facsimile: 03-3642-6698