

OVERVIEW

The ΣDECO SM588× series, fabricated using NPC's Molybdenum-gate CMOS process, are D/A converter ICs for digital audio, that provide all the basic converter functions in miniature 8-pin packages. They each feature built-in 8-times oversampling digital filter, ΣΔ jitter-compensated D/A converter, and post-analog lowpass filter converter stages required for digital audio. They can sample at up to 96kHz for 16 or 24-bit input word length. A type with built-in deemphasis filter is also available for applications requiring deemphasis.

FEATURES

3-wire Input

- 2-channel stereo configuration
- 256fs, 384fs, or 512fs system clock (applied by product/version)
- Input format
3-wire serial, MSB first, rear-packed
16 or 24-bit (applied by product/version)
- 8-times oversampling digital filter
 - 32dB stopband attenuation
 - ±0.05dB passband ripple
- ΣΔ 2-channel D/A converter
 - 3rd-order noise shaper
 - Oversampling operation
- 3rd-order post-analog lowpass filter
- 4.5 to 5.5V supply voltage
- Molybdenum-gate CMOS process
- 8-pin SOP

2-wire Input with Deemphasis Filter

- 2-channel stereo configuration
- 256fs, 384fs, or 512fs system clock (applied by product/version)
- Input format
2-wire serial, MSB first, rear-packed
16 or 24-bit (applied by product/version)
- Deemphasis filter (fs = 44.1kHz sample rate)
- 8-times oversampling digital filter
 - 32dB stopband attenuation
 - ±0.05dB passband ripple
- ΣΔ 2-channel D/A converter
 - 3rd-order noise shaper
 - Oversampling operation
- 3rd-order post-analog lowpass filter
- 4.5 to 5.5V supply voltage
- Molybdenum-gate CMOS process
- 8-pin SOP

PINOUTS

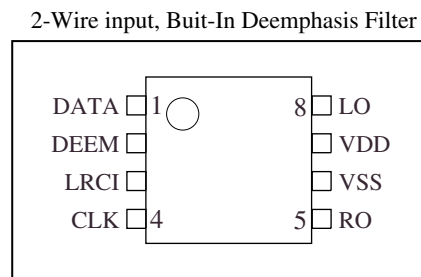
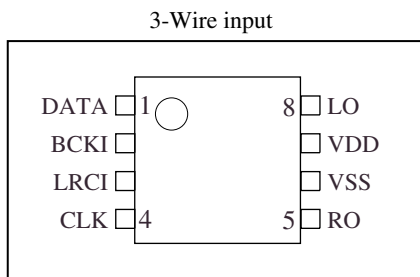

APPLICATIONS

- Audio equipment

ORDERING INFORMATION

Device	Package
SM5882AS	8-pin SOP
SM5883AS	
SM5883BS	
SM5885CS	

PACKAGE DIMENSIONS

(Unit: mm)

Weight: 0.07g

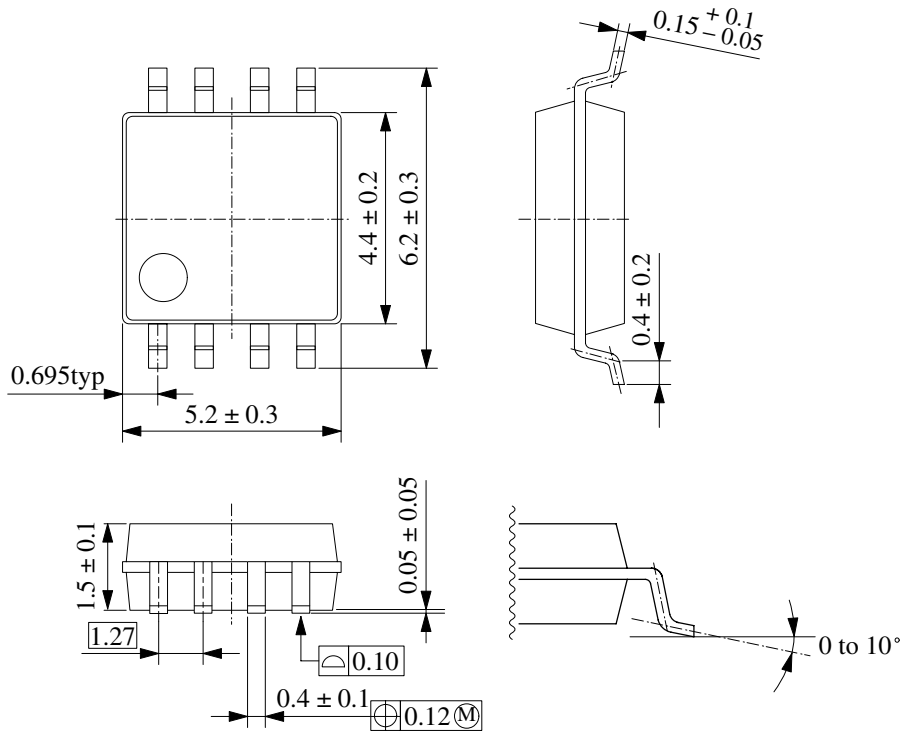

SERIES LINEUP

Device	Input length	Type	Pin 2 function	Master clock
SM5882AS	16	2-wire input	Deemphasis control	384fs
SM5883AS	16	3-wire input	Bit clock input	384fs
SM5883BS	16	3-wire input	Bit clock input	256fs
SM5885CS	24	3-wire input	Bit clock input	512fs

BLOCK DIAGRAM

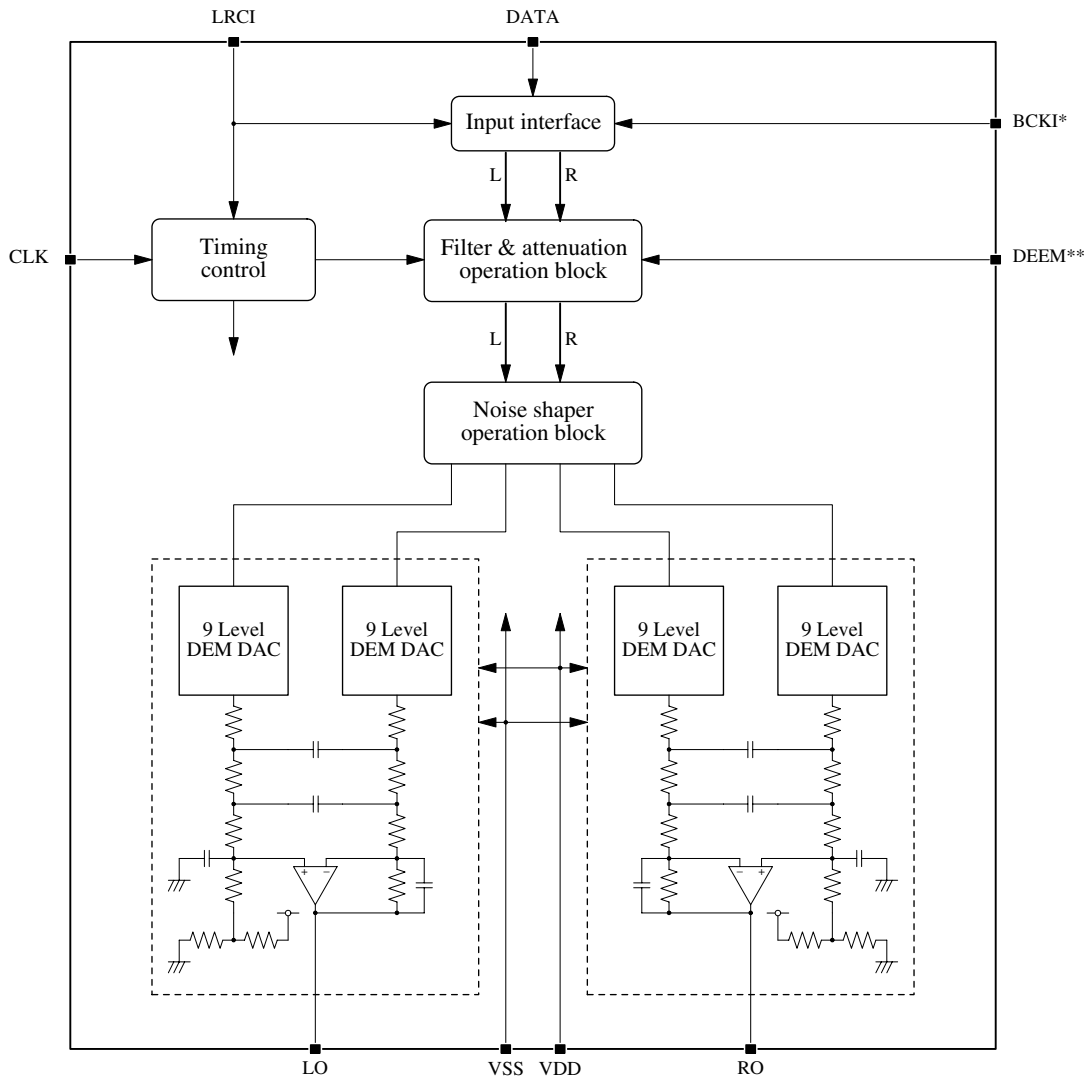

* : Not available for 2-wire input type
 ** : Not available for 3-wire input type

PIN DESCRIPTION

Number	Name	I/O	Description
1	DATA	I	Serial data input
2	BCKI ¹	I	Bit clock input
	DEEM ²	I	Deemphasis ON/OFF control (44.1kHz, ON when HIGH)
3	LRCI	I	Sample rate (fs) clock input. Left-channel input when HIGH, and right-channel input when LOW.
4	CLK	I	External clock input
5	RO	O	Right-channel analog output
6	VSS	-	Ground
7	VDD	-	Supply
8	LO	O	Left-channel analog output

1. 3-wire type
 2. 2-wire type with built-in deemphasis filter

SPECIFICATIONS

Absolute Maximum Ratings

$V_{SS} = 0V$

Parameter	Symbol	Rating	Unit
Supply voltage range	V_{DD}	-0.3 to 7.0	V
Input voltage range ¹	V_{IN}	$V_{SS} - 0.3$ to $V_{DD} + 0.3$	V
Storage temperature range	T_{STG}	-55 to 125	°C
Power dissipation	P_D	300	mW

1. All inputs

Also applicable during supply switching.

Recommended Operating Conditions

$V_{SS} = 0V$

Parameter	Symbol	Rating	Unit
Supply voltage	V_{DD}	4.5 to 5.5	V
Operating temperature	T_{OPR}	-40 to 85	°C

DC Characteristics

$V_{DD} = 4.5$ to $5.5V$, $V_{SS} = 0V$, $T_a = -40$ to $85^\circ C$

Parameter	Symbol	Condition	Rating			Unit
			min	typ	max	
Current consumption ¹	I_{DD}		-	12.5	25.0	mA
CLK HIGH-level input voltage	V_{IH1}	Clock input	$0.7V_{DD}$	-	-	V
CLK LOW-level input voltage	V_{IL1}	Clock input	-	-	$0.3V_{DD}$	V
CLK AC-coupled input voltage	V_{INAC}		0.7	-	-	V_{p-p}
HIGH-level input voltage ²	V_{IH2}		$0.5V_{DD}$	-	-	V
LOW-level input voltage ²	V_{IL2}		-	-	$0.2V_{DD}$	V
CLK HIGH-level input current	I_{IH}	$V_{IN} = V_{DD}$	20	62	170	μA
CLK LOW-level input current	I_{IL}	$V_{IN} = 0V$	20	62	170	μA
Input leakage current ²	I_{LH}	$V_{IN} = V_{DD}$	-	-	1.0	μA
	I_{LL}	$V_{IN} = 0V$	-	-	1.0	μA

1. $V_{DD} = 5V$, CLK clock input frequency $f_{CLK} = 16.9344MHz$ (384fs type)/ $11.2896MHz$ (256fs type)/ $22.5792MHz$ (512fs type), no output load.
Input data: NPC pattern.

2. Pins BCKI (3-wire type), DEEM (2-wire type with deemphasis filter), DATA, LRCI

AC Digital Characteristics

$V_{DD} = 4.5$ to $5.5V$, $V_{SS} = 0V$, $T_a = -40$ to $85^{\circ}C$

System clock (CLK)

256fs type

Parameter	Symbol	Rating			Unit
		min	typ	max	
HIGH-level clock pulsewidth	t_{CWH}	20.0	–	125	ns
LOW-level clock pulsewidth	t_{CWL}	20.0	–	125	ns
Clock pulse cycle	t_{XI}	40.0	–	250	ns

384fs type

Parameter	Symbol	Rating			Unit
		min	typ	max	
HIGH-level clock pulsewidth	t_{CWH}	13.15	–	125	ns
LOW-level clock pulsewidth	t_{CWL}	13.15	–	125	ns
Clock pulse cycle	t_{XI}	26.3	–	250	ns

512fs type

Parameter	Symbol	Rating			Unit
		min	typ	max	
HIGH-level clock pulsewidth	t_{CWH}	10	–	125	ns
LOW-level clock pulsewidth	t_{CWL}	10	–	125	ns
Clock pulse cycle	t_{XI}	20	–	250	ns

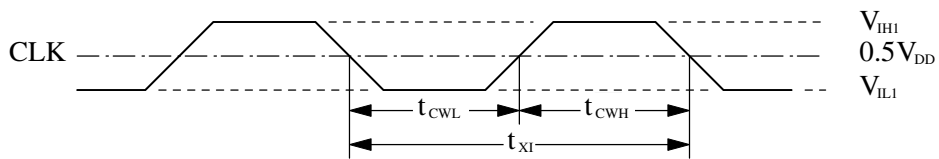

Serial inputs

3-wire type (BCKI, DATA, LRCI)

Parameter	Symbol	Rating			Unit
		min	typ	max	
BCKI HIGH-level pulsewidth	t_{BCWH}	50.0	–	–	ns
BCKI LOW-level pulsewidth	t_{BCWL}	50.0	–	–	ns
BCKI pulse cycle	t_{BCY}	1/(64fs)	–	–	ns
DATA setup time	t_{DS}	50.0	–	–	ns
DATA hold time	t_{DH}	50.0	–	–	ns
LRCI edge to first BCKI rising edge	t_{LB}	50.0	–	–	ns
Last BCKI rising edge to LRCI edge	t_{BL}	50.0	–	–	ns

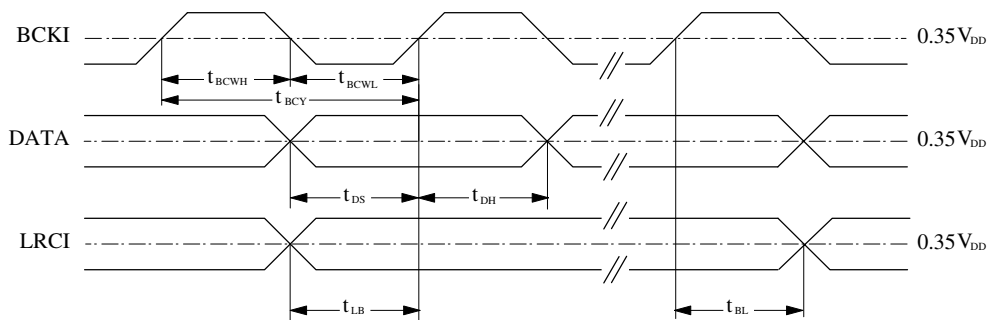

2-wire type (DATA, LRCI)

Parameter	Symbol	Condition	Rating			Unit
			min	typ	max	
DATA setup time	t_{DS}		50	–	–	ns
DATA hold time	t_{DH}		50	–	–	ns
LRCI edge to internal BCLK rising edge	t_{LB}	256fs/512fs	$1.5t_{X1}$	–	$2.5t_{X1}$	ns
		384fs	$3.5t_{X1}$	–	$4.5t_{X1}$	ns

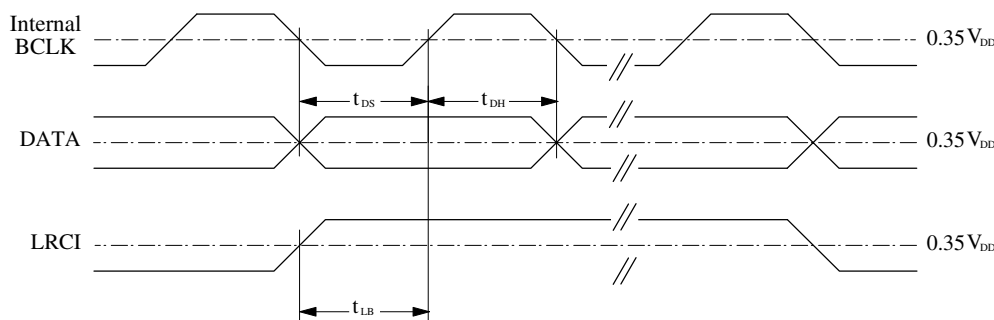

Control input (DEEM: 2-wire type)

Parameter	Symbol	Rating			Unit
		min	typ	max	
Rise time	t_r	–	–	50	ns
Fall time	t_f	–	–	50	ns



AC Analog Characteristics

256fs type specification (SM5883BS) : $V_{SS} = 0V$, $V_{DD} = 5V$, 16-bit input type,
crystal oscillator frequency $f_{OSC} = 11.2896MHz$, $T_a = 25^\circ C$

Parameter	Symbol	Condition	Rating			Unit
			min	typ	max	
Total harmonic distortion	THD + N	1kHz, 0dB	–	0.0035	0.0130	%
LSI output level	V_{OUT1}	1kHz, 0dB	–	1.09	–	V_{rms}
Evaluation board output level	V_{OUT2}	1kHz, 0dB	–	1.33	–	V_{rms}
Dynamic range	D.R	1kHz, –60dB	90.4	96.4	–	dB
Signal-to-noise ratio	S/N	1kHz, 0dB/ $-\infty$	92.8	98.8	–	dB
Channel separation	Ch. Sep	1kHz, $-\infty$ –0dB	87.5	93.5	–	dB

Note. These parameters are measured using the measurement block diagram (page 8) and the measurement circuit (page 9).

384fs type specification (SM5882AS, SM5883AS) : $V_{SS} = 0V$, $V_{DD} = 5V$, DEEM = 0V (2-wire type),
16-bit input type, crystal oscillator frequency $f_{OSC} = 16.9344MHz$, $T_a = 25^\circ C$

Parameter	Symbol	Condition	Rating			Unit
			min	typ	max	
Total harmonic distortion	THD + N	1kHz, 0dB	–	0.003	0.0120	%
LSI output level	V_{OUT1}	1kHz, 0dB	–	1.09	–	V_{rms}
Evaluation board output level	V_{OUT2}	1kHz, 0dB	–	1.33	–	V_{rms}
Dynamic range	D.R	1kHz, –60dB	90.4	96.4	–	dB
Signal-to-noise ratio	S/N	1kHz, 0dB/ $-\infty$	93.0	99.0	–	dB
Channel separation	Ch. Sep	1kHz, $-\infty$ –0dB	88.5	94.5	–	dB

Note. These parameters are measured using the measurement block diagram (page 8) and the measurement circuit (page 9).

512fs type specification (SM5885CS) : $V_{SS} = 0V$, $V_{DD} = 5V$, 24-bit input type,
crystal oscillator frequency $f_{OSC} = 22.5792MHz$, $T_a = 25^\circ C$

Parameter	Symbol	Condition	Rating			Unit
			min	typ	max	
Total harmonic distortion	THD + N	1kHz, 0dB	–	0.0035	0.0130	%
LSI output level	V_{OUT1}	1kHz, 0dB	–	1.09	–	V_{rms}
Evaluation board output level	V_{OUT2}	1kHz, 0dB	–	1.33	–	V_{rms}
Dynamic range	D.R	1kHz, –60dB	92.0	98.0	–	dB
Signal-to-noise ratio	S/N	1kHz, 0dB/ $-\infty$	92.8	98.8	–	dB
Channel separation	Ch. Sep	1kHz, $-\infty$ –0dB	87.5	93.5	–	dB

Note. These parameters are measured using the measurement block diagram (page 8) and the measurement circuit (page 9).

AC analog measurement block diagram

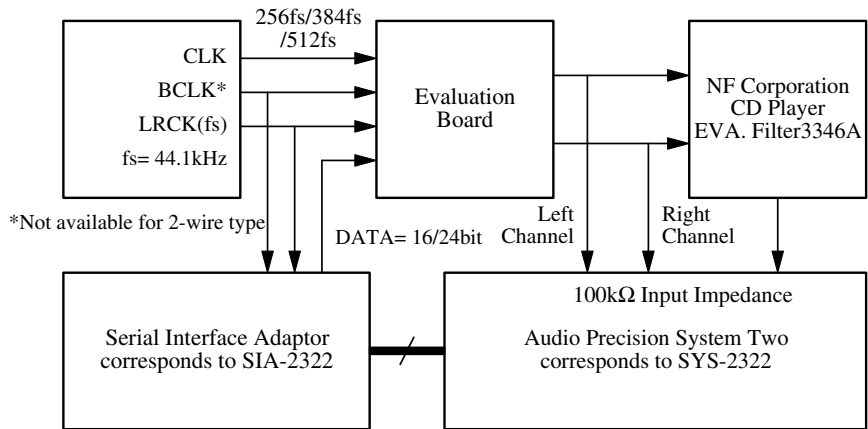

AC analog measurement conditions

Parameter ¹	Symbol	3346A left/right-channel selector switch	Audio Precision System Two audio analyzer with built-in filter
Total harmonic distortion	THD + N	Not used	20kHz lowpass filter
Output level	V _{OUT}		
Dynamic range	D.R	D-RANGE	
Signal-to-noise ratio	S/N	Not used	22kHz lowpass filter A-WTD
Channel separation	Ch. Sep	Not used	20kHz lowpass filter

1. Pins LO and RO should have an output load of 10kΩ (min).

Theoretical Filter Characteristics

Overall characteristics

Parameter	Frequency band		Attenuation [dB]		
	f	@ fs = 44.1kHz	min	typ	max
Passband ripple	0 to 0.4535fs	0 to 20.0kHz	-0.05	-	+0.05
Stopband attenuation	0.5465fs to 7.4535fs	24.1 to 328.7kHz	32	-	-
Built-in analog LPF compensation	0.4535fs	20.0kHz	-	-0.34	-

Overall frequency characteristic

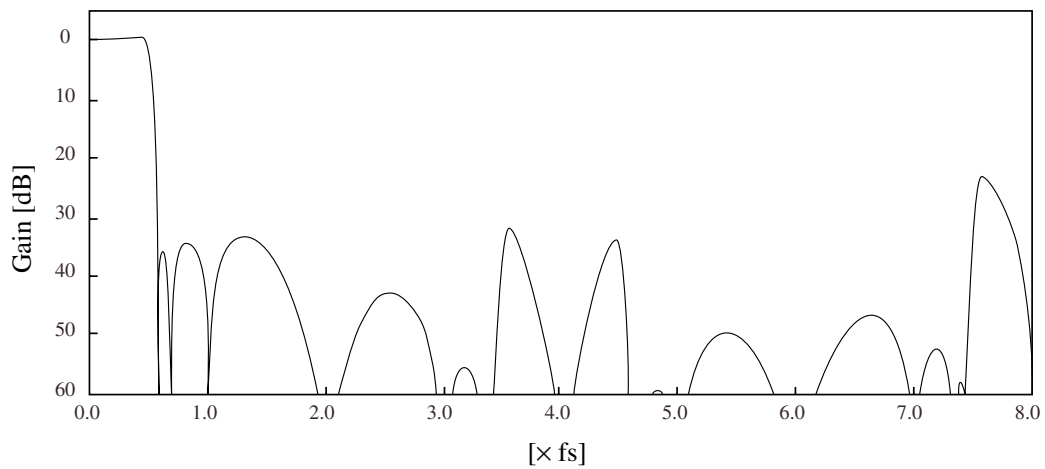

Passband characteristic

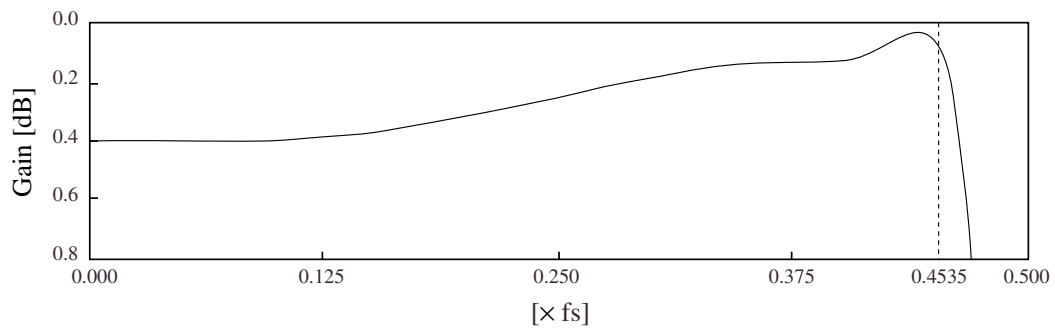

2-wire input, deemphasis ON overall characteristics

Parameter	Frequency band		Attenuation [dB]		
	f	@ fs = 44.1kHz	min	typ	max
Passband ripple	0 to 0.4535fs	0 to 20.0kHz	-0.09	-	+0.23
Stopband attenuation	0.5465fs to 7.4535fs	24.1 to 328.7kHz	36	-	-
Built-in analog LPF compensation	0.4535fs	20.0kHz	-	-0.34	-

Deemphasis ON overall frequency characteristic

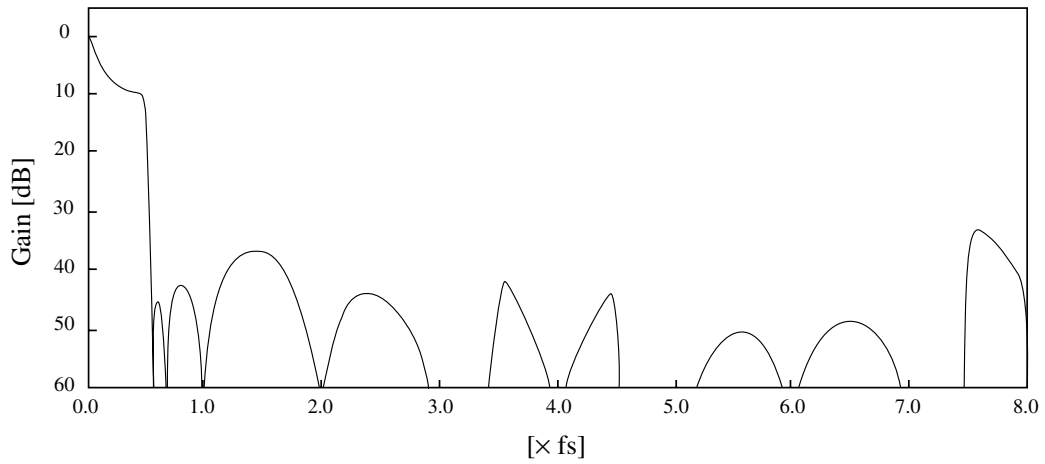

Deemphasis ON passband characteristic

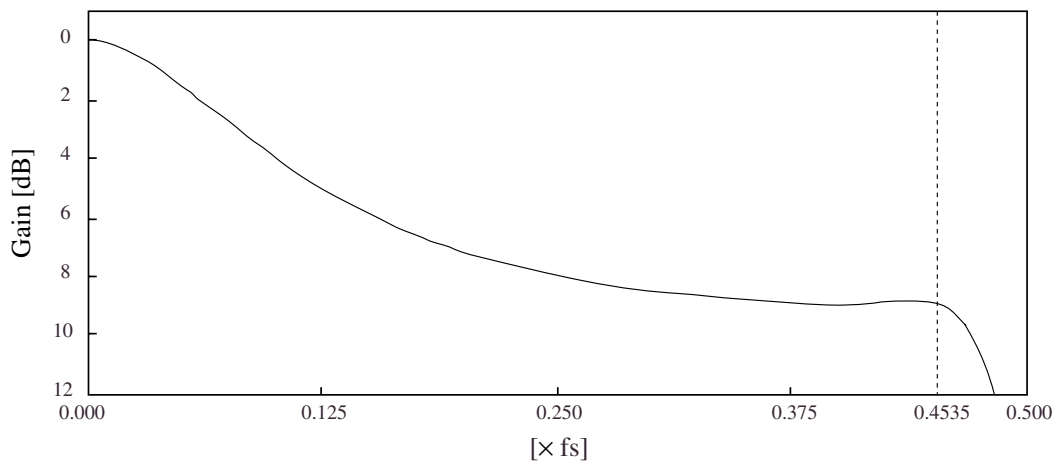

FUNCTIONAL DESCRIPTION

System Clock (CLK)

The system clock CLK frequency varies with device within the series as shown below, where f_s is the input frequency on LRCI.

Note that the input clock accuracy and signal-to-noise ratio greatly influence the AC analog characteristics. The D/A converter operates at the speed shown in the following table.

Table 1. System clock

Device	Master clock	DAC oversampling operation
A version	384 f_s	48 f_s
B, C version	256/512 f_s	32 f_s

System Reset

The SM588× series devices incorporate a built-in power-ON reset circuit for system reset.

When power is applied, the internal arithmetic operation and output timing counter are reset, and then reset again and timing synchronized to the external input on the next LRCI rising edge. After system reset, the outputs are muted until the 9th rising of LRCI when output muting is released.

When the timing is reset, the PWM outputs may generate an output noise. An external muting circuit may be required to prevent this output noise.

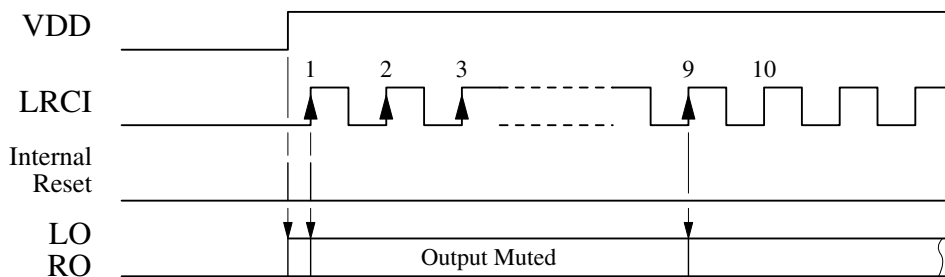

Figure 1. System reset timing

Audio Data Input

Input data format (DATA)

The input data has a format that varies with device within the series, as shown below.

Table 2. Input format

Device	Input length	Format
SM5882/SM5883 ¹	16bits	MSB first, bit serial, rear-packed, 2s complement
SM5885 ²	24bits	

1. The 2-wire type supports bit clocks of 48fs (384fs) or 64fs (256fs/512fs) only.
2. The 3-wire type supports bit clocks of up to 64fs.

Input timing

3-wire input (DATA, LRCI, BCKI)

Serial data bits on DATA are read into the SIPO register (serial-to-parallel converter register) on the rising edge of the bit clock BCKI, and then converted to parallel data.

The arithmetic operation and output timing are independent of the input timing. Accordingly, after a reset, as long as the clock frequency ratio between LRCI and the system clock CLK is maintained, phase differences between LRCI, BCKI and the system clock CLK do not affect the functional operation. Also, any jitter present on the data input clock does not appear as output pulse jitter.

2-wire input (DATA, LRCI)

Serial data bits on DATA are read into the SIPO register (serial-to-parallel converter register) on the rising edge of an internally generated bit clock, and then converted to parallel data.

Deemphasis Filter (DEEM: 2-wire input)

The 2-wire type with built-in digital deemphasis filter is designed to operate at 44.1kHz. Deemphasis is ON when DEEM is HIGH, and OFF when DEEM is LOW.

TIMING DIAGRAMS

2-wire Input Type with Deemphasis Filter Built-in

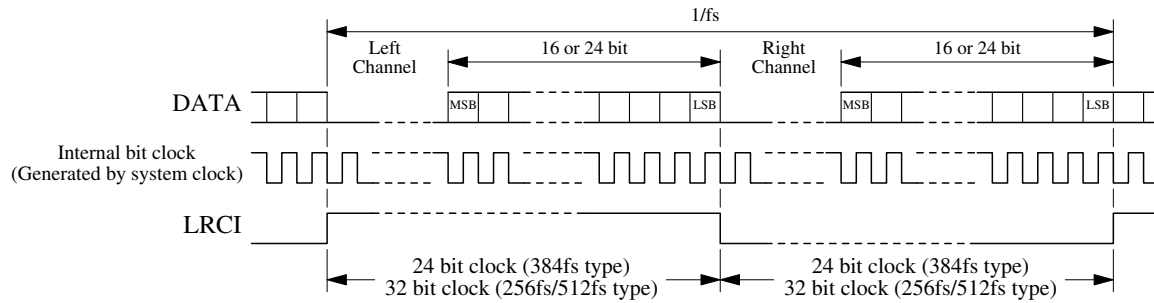

3-wire Input Type

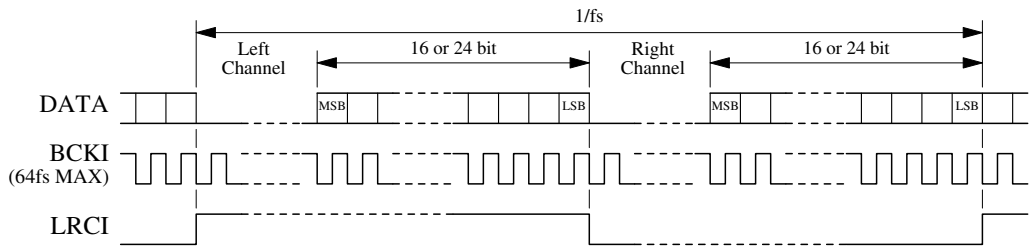

TYPICAL APPLICATIONS

Input Interface Examples ($f_s = 44.1\text{kHz}$)

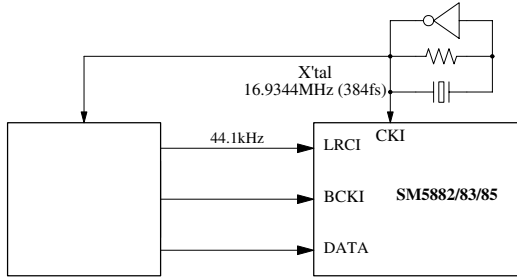

3-wire input type
System clock 384fs

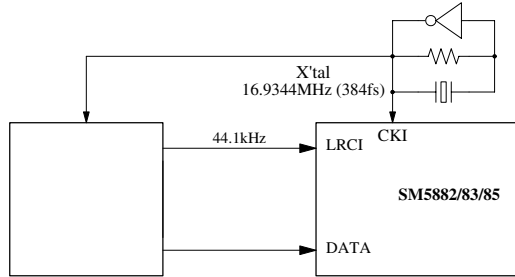

2-wire input type
System clock 384fs

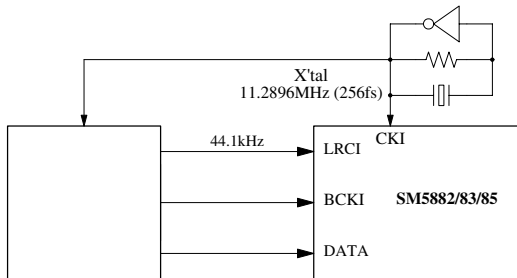

3-wire input type
System clock 256fs

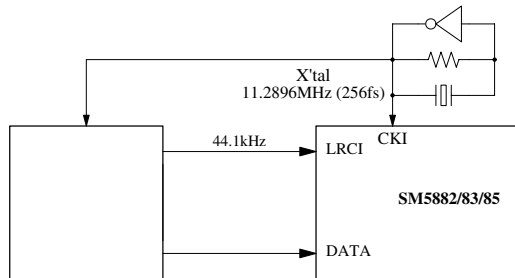

2-wire input type
System clock 256fs

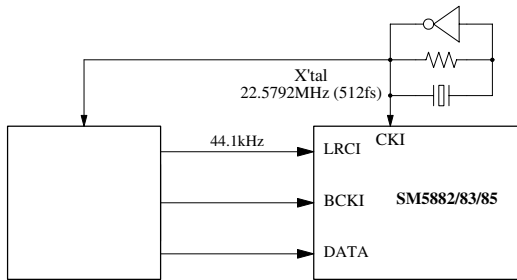

3-wire input type
System clock 512fs

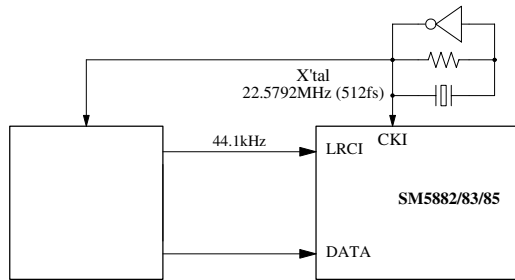

2-wire input type
System clock 512fs

Note that the output analog characteristics and other specifications are not guaranteed for a particular format or application circuit.

Please pay your attention to the following points at time of using the products shown in this document.

The products shown in this document (hereinafter "Products") are not intended to be used for the apparatus that exerts harmful influence on human lives due to the defects, failure or malfunction of the Products. Customers are requested to obtain prior written agreement for such use from SEIKO NPC CORPORATION (hereinafter "NPC"). Customers shall be solely responsible for, and indemnify and hold NPC free and harmless from, any and all claims, damages, losses, expenses or lawsuits, due to such use without such agreement. NPC reserves the right to change the specifications of the Products in order to improve the characteristic or reliability thereof. NPC makes no claim or warranty that the contents described in this document dose not infringe any intellectual property right or other similar right owned by third parties. Therefore, NPC shall not be responsible for such problems, even if the use is in accordance with the descriptions provided in this document. Any descriptions including applications, circuits, and the parameters of the Products in this document are for reference to use the Products, and shall not be guaranteed free from defect, inapplicability to the design for the mass-production products without further testing or modification. Customers are requested not to export or re-export, directly or indirectly, the Products to any country or any entity not in compliance with or in violation of the national export administration laws, treaties, orders and regulations. Customers are requested appropriately take steps to obtain required permissions or approvals from appropriate government agencies.

The logo for NPC (Seiko NPC Corporation) consists of the letters 'NPC' in a bold, black, sans-serif font. The 'N' and 'P' are connected at the top, and the 'C' is positioned to the right of the 'P'.

SEIKO NPC CORPORATION

15-6, Nihombashi-kabutocho, Chuo-ku,
Tokyo 103-0026, Japan
Telephone: +81-3-6667-6601
Facsimile: +81-3-6667-6611
<http://www.npc.co.jp/>
Email: sales@npc.co.jp

NC9720HE 2006.04