

## OVERVIEW

The SM6780AS is a quick charge control IC for Nickel-Cadmium (Ni-Cd) and Nickel Metal Hydride (Ni-MH) rechargeable batteries. It supports quick charge, supplemental and pulse trickle charging modes. The charging mode is selected automatically in response to the battery voltage, temperature and charging time. The quick charge uses either negative delta voltage detection ( $-\Delta V$ ), temperature detection ( $\Delta T/\Delta t$ ), or charging time cut-off to control the charging process. In addition, the quick charge mode can be placed on hold, if the battery voltage or battery temperature are abnormal, until normal conditions are restored. The SM6780AS requires few external components to realize a high-stability quick charge battery charger.

## FEATURES

- Ni-Cd/Ni-MH battery quick charge control
- $-\Delta V$ ,  $\Delta T/\Delta t$ , and maximum charge time cutoffs
- 3 charge modes  
(quick charge, supplemental, pulse trickle charge)
- 3 selectable charge times  
(80, 120, and 240 minutes)
- Charge condition LED indicator output  
(on, pulsed, off)
- Low power dissipation mode
- 4.0 to 5.5V operating supply voltage
- 300sec (typ)  $-\Delta V$  detection invalid time
- 8mV (typ)  $-\Delta V$  detection accuracy
- 25mV/min (typ)  $\Delta T/\Delta t$  detection accuracy
- 8-pin SOP package

## ORDERING INFORMATION

Device	Package
SM6780AS	8-pin SOP

## PINOUT

(Top view)

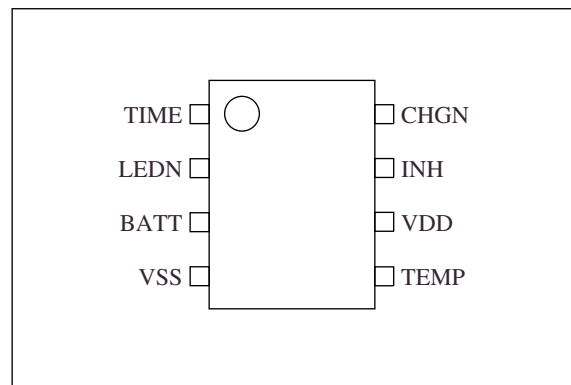

## PACKAGE DIMENSIONS

(Unit: mm)

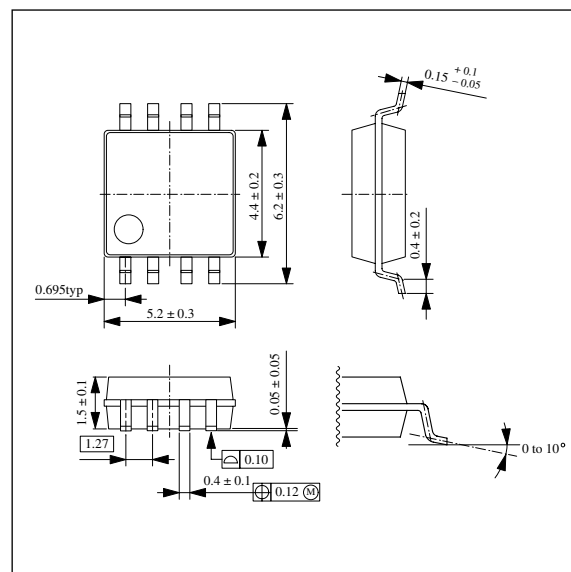

**BLOCK DIAGRAM**

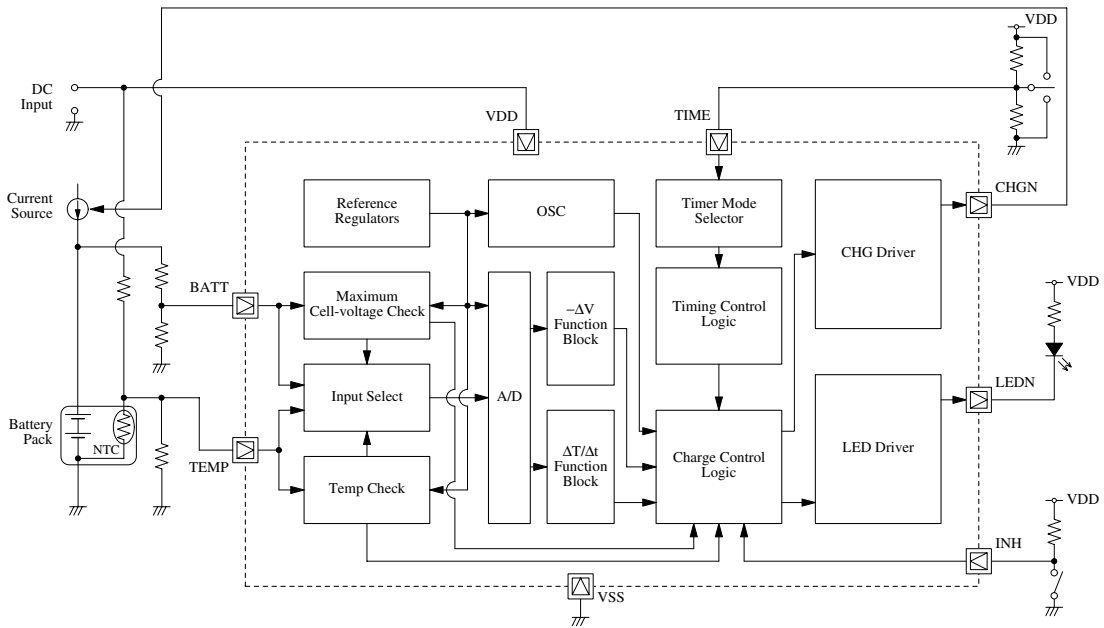

**PIN DESCRIPTION**

Number	Name	Description
1	TIME	Charge time select 3-level input. HIGH: 240 minutes, MID ( $V_{DD}/2$ ): 120 minutes, LOW: 80 minutes
2	LEDN	Charge indicator LED driver output. Open-drain output. LOW-level output in quick charge mode. 1Hz pulse output when abnormal battery voltage or temperature is detected during quick charge mode. High impedance output in supplemental and trickle charge modes.
3	BATT	Battery voltage detector input. Connect a high-impedance resistor voltage divider between the poles of the battery for voltage detection.
4	VSS	Ground
5	TEMP	Battery temperature thermistor sensor voltage input
6	VDD	Supply
7	INH	Charge inhibit input. Charging is stopped when HIGH. Charging resumes with the same charge parameters in force prior to the stop when INH goes LOW again.
8	CHGN	Charger control output. Open-drain output. Battery charging current flows when CHGN is high impedance. Charge current stops when LOW. High-impedance output in quick charge mode, and pulse output in supplemental and trickle charge modes.

## SPECIFICATIONS

### Absolute Maximum Ratings

$$V_{SS} = 0V$$

Parameter	Symbol	Condition	Rating	Unit
Supply voltage range	$V_{DD}$		-0.3 to 7.0	V
Input voltage range	$V_{IN}$		-0.3 to 7.0	V
Storage temperature range	$T_{stg}$		-55 to 125	°C
Operating temperature range	$T_{opr}$		0 to 85	°C
Power dissipation	$P_D$		150	mW

### DC Characteristics 1

$$V_{DD} = 4.0 \text{ to } 5.5V, V_{SS} = 0V, T_a = 25^\circ C$$

Parameter	Symbol	Condition	Rating	Variation	Unit
Maximum temperature voltage	$V_{MXT}$	$V_{TEMP} \leq V_{MXT}$ charge cutoff	$0.225V_{DD}$	±5%	V
High-temperature sense voltage	$V_{HTS}$	$V_{HTS} \leq V_{TEMP} \leq V_{LTS}$ charge start	$0.25V_{DD}$	±5%	V
Low-temperature sense voltage	$V_{LTS}$	$V_{TEMP} > V_{LTS}$ charge prohibition	$0.4V_{DD}$	±5%	V
Maximum battery voltage	$V_{MXV}$	$V_{BATT} > V_{MXV}$ charge cutoff or prohibition	2.0	±5%	V

### DC Characteristics 2

$$V_{DD} = 4.0 \text{ to } 5.5V, V_{SS} = 0V, T_a = 0 \text{ to } 85^\circ C \text{ unless otherwise noted.}$$

Parameter	Symbol	Condition	Rating			Unit
			min	typ	max	
VDD supply voltage	$V_{DD}$		4.0	5.0	5.5	V
BATT input voltage	$V_{BATT}$		0	-	$V_{DD}$	V
TEMP input voltage	$V_{TEMP}$	Disabled when $V_{TEMP} < 0.5V$	0.5	-	$V_{DD}$	V
INH HIGH-level input voltage	$V_{IH1}$		0.7	-	-	V
INH LOW-level input voltage	$V_{IL1}$		-	-	0.1	V
TIME HIGH-level input voltage	$V_{IH2}$		$V_{DD} - 0.5$	-	-	V
TIME MID-level input voltage	$V_{IM}$		$(V_{DD}/2) - 0.5$	-	$(V_{DD}/2) + 0.5$	V
TIME LOW-level input voltage	$V_{IL2}$		-	-	0.5	V
BATT -ΔV detection voltage range	$V_{DET}$		1	-	2	V
LEDN output pulse frequency	$f_{LED}$		-	1	-	Hz
BATT standby voltage	$V_{STB}$		$V_{DD} - 1.5$	-	$V_{DD} - 0.5$	V
VDD current consumption	$I_{DD}$	$V_{DD} = 5V$ , no load	-	-	0.5	mA
VDD standby current	$I_{STB}$	$V_{DD} = 5V$ , $V_{BATT} = V_{DD}$ , no load	-	-	1	μA
LEDN, CHGN sink current	$I_{OL}$	$V_{OL} = V_{SS} + 0.8V$	10	-	-	mA
INH, TIME input leakage current	$I_L$	$V_{INH} = V_{TIME} = V_{SS}$ to $V_{DD}$	-	-	±1	μA
LEDN, CHGN output leakage current	$I_{OZ}$		-5	-	-	μA

## FUNCTIONAL DESCRIPTION

### Charger Operation

The SM6780AS battery charger operation starts when the power is applied or when standby mode is released. The charging operation is determined by the BATT and TEMP pin states, and the timer mode selected.

After charging starts, the battery voltage and temperature are monitored to check that they are within quick charging rated ranges. If within rated range, quick charge mode is selected. If outside rated range, pulse trickle charge mode is selected.

Quick charge uses either negative delta voltage detection ( $-\Delta V$ ), temperature detection ( $\Delta T/\Delta t$ ), or charging time cutoff to terminate the charging process. The charging mode changes to supplemental charge mode when quick charge mode is completed.

Supplemental mode terminates when the charging time finishes or battery is full, and the charging mode changes to pulse trickle mode.

### Charging Rate

The charging rate is determined by the external charger current source. If the quick charge mode charging rate is considered as unity, then the supplemental charging rate is 1/16, and the pulse trickle charging rate is 1/256. The charging rate for supplemental and pulse trickle modes are shown in figure 1. The CHGN output is high impedance when the charging current is flowing, and LOW when the current stops.

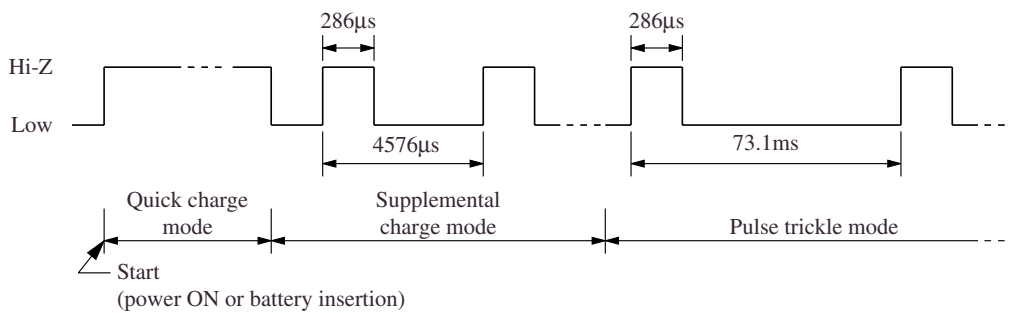

Figure 1. CHGN output (external charger control)

### Charging Status Indicator LED Control (LEDN)

The SM6780AS LEDN output can be used to drive a charging status indicator LED.

The LED timing when power is applied or standby mode is released is shown in figure 2.

In quick charge mode, the LEDN output is LOW and the LED turns ON. If the battery temperature or battery voltage exceeds the charging rated ranges, the LEDN output pulses at a frequency of 1Hz to indicate battery out-of-range condition. In supplemental and pulse trickle modes, the LEDN output is high impedance and the LED turns OFF.

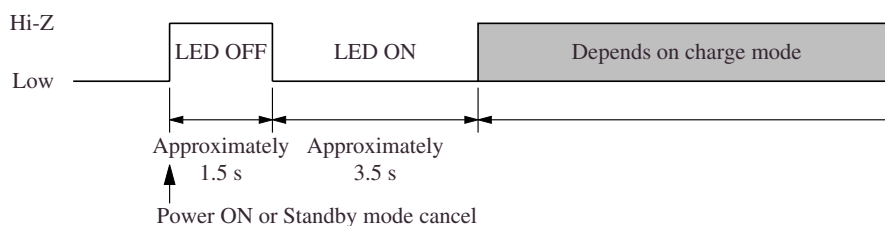

Figure 2. LEDN output timing

## Battery Voltage and Temperature Detection

The battery voltage detector input is BATT. The charger treats the input voltage as the equivalent voltage of a single cell. For multiple cells (connected in series), a high-resistance ( $> 100\text{k}\Omega$ ) battery divider can be used to input the voltage equivalent of a single cell, as shown in figure 3. For single cell, a high-resistance ( $> 100\text{k}\Omega$  for current limit) is connected between battery and BATT pin as shown in figure 4.

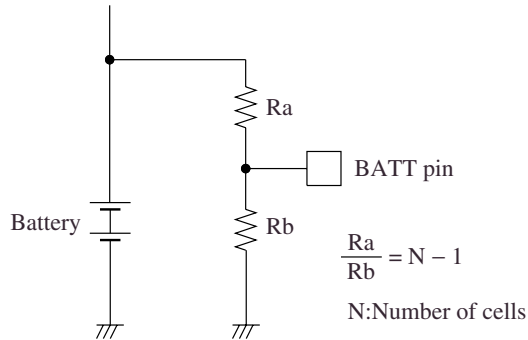

Figure 3. BATT connection example (multiple)

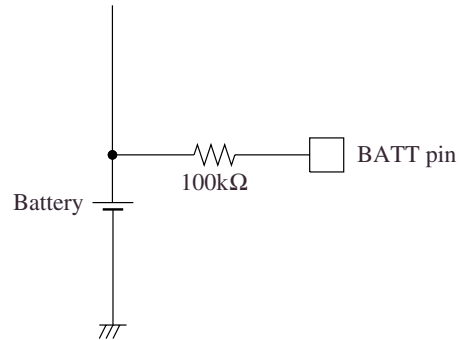

Figure 4. BATT connection example (single)

The battery temperature detector input is TEMP. The input voltage is provided by a negative temperature coefficient thermistor (NTC thermistor) located in close proximity to the battery, as shown in figure 5. The input voltage range is  $0.5\text{V}$  to  $V_{\text{DD}}$ .

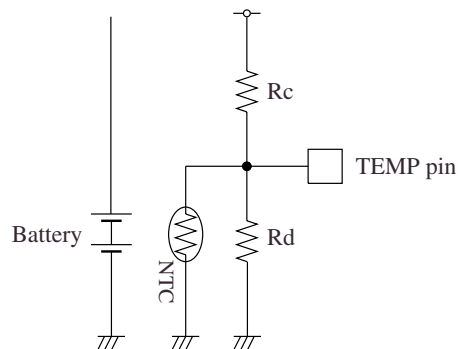

Figure 5. TEMP connection example

Note that the thermistor temperature characteristics are non-linear, so a correction resistance  $R_d$  should be used for linearity correction. The temperature rating of resistances  $R_c$  and  $R_d$  should be chosen to match the battery temperature range rating. If the temperature detection function is not used, the TEMP input should be fixed at a potential in the range  $0.25V_{\text{DD}}$  to  $0.4V_{\text{DD}}$ .

### Charging Modes

The SM6780AS has 3 modes of operation: quick charge, supplemental charge, and pulse trickle mode.

The SM6780AS uses the various detection functions to monitor the state of the battery and select the charging mode automatically.

In quick charge mode, charging occurs at a rate set by the external current source. In supplemental charge mode, the battery is charged by current pulses to the full stable capacity of the chemical substances within the battery. Pulse trickle mode maintains the level within the battery, compensating for internal losses.

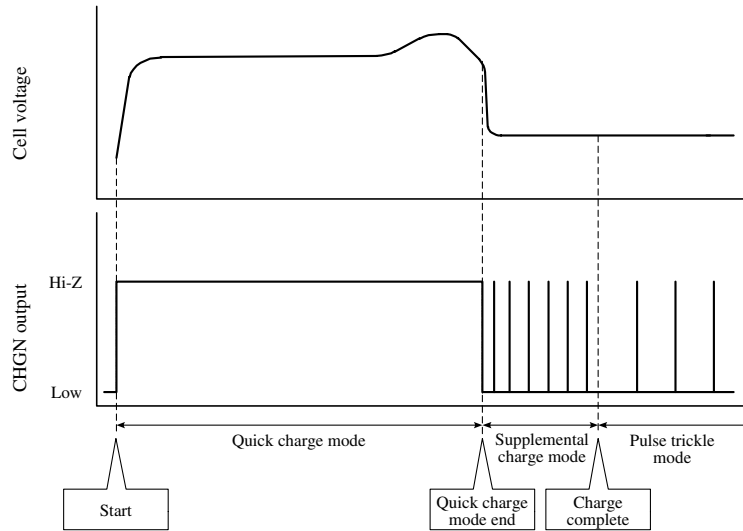

Figure 6. Charging mode, battery voltage and charging current

### Quick (Supplemental) Charge Conditions — Battery Check

The SM6780AS monitors the battery voltage and battery temperature to confirm the values are within the rated range of the battery during quick charge and supplemental charging modes to realize a high-stability battery charger.

If the battery voltage or battery temperature charging rating is exceeded before quick charging mode terminates, the charging mode is placed on hold. The internal timer continues to operate, and pulse trickle charging occurs. The LEDN output pulses at a rate of approximately 1Hz. If the charging rating is exceeded during supplemental charging mode, the mode terminates and charging switches to pulse trickle mode.

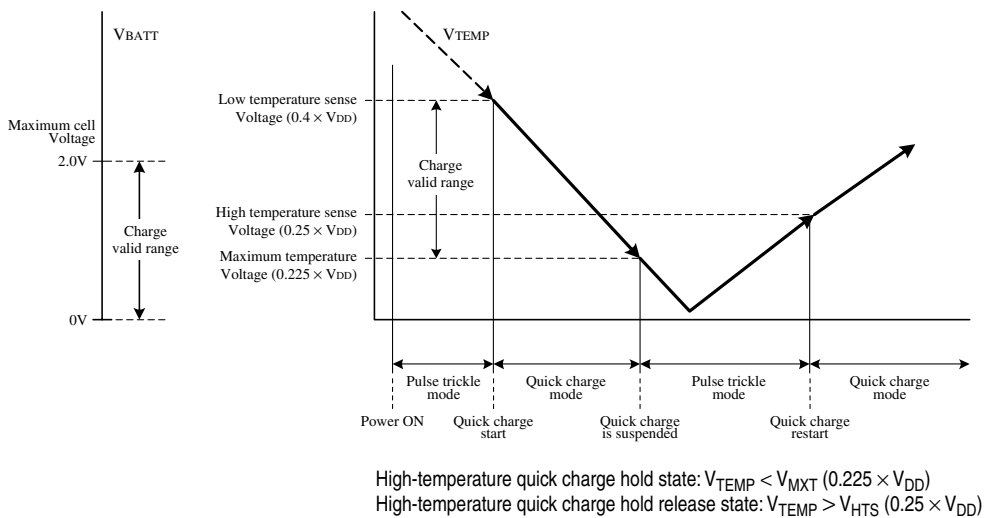

Figure 7. Quick (supplemental) charge ranges

**-ΔV Invalid Time**

Generally, the battery voltage becomes unstable just after quick charging starts, so the -ΔV battery voltage detection is disabled for 5 minutes to avoid error in battery voltage detection. However, the ΔT/Δt temperature detection function continues to operate. After the -ΔV detection is enabled, both detection functions operate.

**-ΔV Detection (BATT)**

After Ni-Cd and Ni-MH batteries are fully charged in quick charge mode, the battery voltage begins to drop after reaching a peak value. The SM6780AS monitors the delta voltage (-ΔV) to help determine when the battery is fully charged. When the voltage has fallen a minimum of 8mV (typ), the battery is fully charged and quick charge mode terminates.

Note that -ΔV detection is disabled for 5 minutes when quick charge mode is first started to avoid error in battery voltage detection, as described in the previous section.

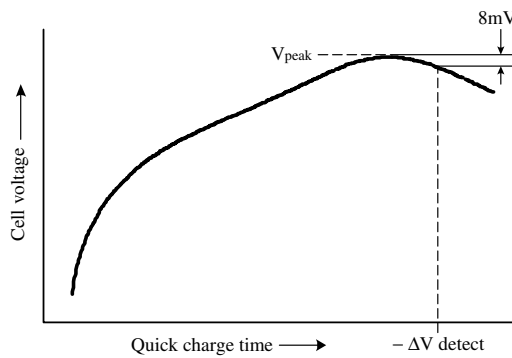

Figure 8. Battery voltage change

**ΔT/Δt Detection (TEMP)**

When Ni-Cd and Ni-MH batteries are close to full charge in quick charge mode, the temperature of the battery begins to greatly increase. The SM6780AS monitors the temperature change rate (ΔV/Δt) to help determine when the battery is fully charged. When the temperature voltage on TEMP decreases by a minimum of 25mV (typ) within a 60-second interval, the battery is considered to be fully charged and quick charge mode terminates.

Note that the TEMP voltage decreases with increasing temperature due to the negative temperature coefficient of the thermistor.

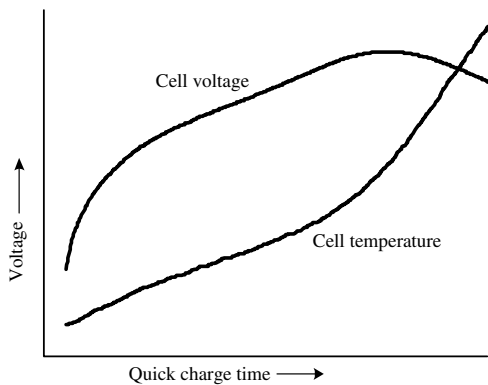

Figure 9. Battery temperature change

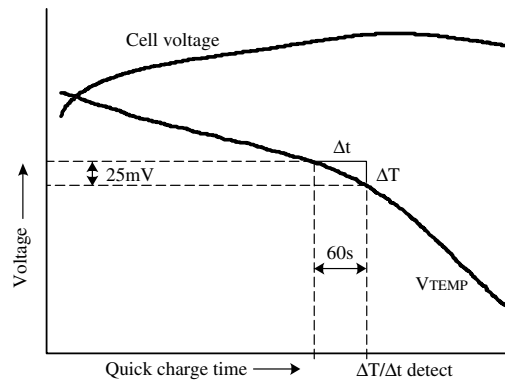

Figure 10. V<sub>TEMP</sub> change

### Maximum Charging Time (TIME)

The SM6780AS supports 3 different maximum charging time settings, in quick charge and supplemental charge modes, which can be selected on the 3-level input TIME (HIGH, MID, LOW). HIGH level is achieved by pull-up, LOW level by pull-down, and MID level by a high-resistance voltage divider arrangement to set the voltage at  $V_{DD}/2$ . The voltage level on TIME should only be switched in standby mode.

$V_{DD} = 5V$ ,  $T_a = 25^{\circ}C$

TIME voltage level	Quick charge/supplemental charge time (minutes)		
	min	typ	max
HIGH	192	240	288
MID	96	120	144
LOW	64	80	96

### Quick (Supplemental) Charge Inhibit (INH)

When INH goes HIGH, quick charge mode or supplemental charge mode operation stops. While INH is HIGH, the internal timer stops and pulse trickle charging occurs. When INH goes LOW, the charging mode is restored to the previously active mode and the internal timer restarts.

### Standby Mode

When the BATT input voltage is  $\geq V_{STB}$ , the SM6780AS is in standby mode. In this mode, the internal timer is reset, and the LEDN and CHGN outputs become high impedance. Standby mode is released when the voltage applied to BATT falls below  $V_{STB}$ .

### Charging Flow Diagram

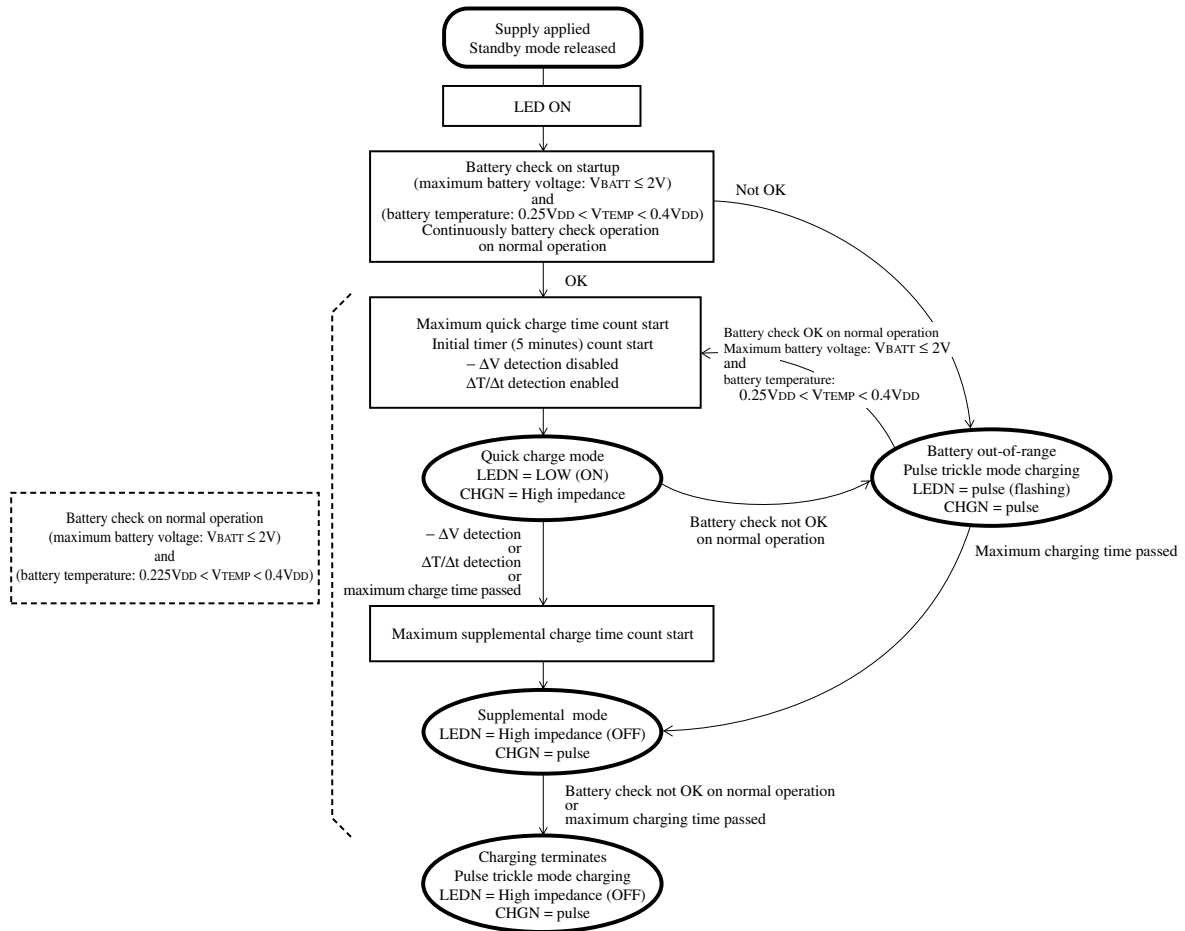

### Charging Operating Status

Charging status	Conditions		Charging mode	CHGN output <sup>1</sup>	LEDN output	Internal timer
	INH	Battery check OK				
Quick charge	LOW	Yes	Quick charge	High impedance	LOW (ON)	Count
Quick charge hold	LOW	No	Pulse trickle	13.68Hz, 0.39% duty	1Hz (pulsing)	Count
Quick charge inhibit	HIGH	–	Pulse trickle	13.68Hz, 0.39% duty	Same condition as when INH went HIGH	Hold
Supplemental charge	LOW	OK	Supplemental	218Hz, 6.25% duty	High impedance (OFF)	Count
Supplemental charge inhibit	HIGH	OK	Pulse trickle	13.68Hz, 0.39% duty	High impedance (OFF)	Hold
Pulse trickle	–	–	Pulse trickle	13.68Hz, 0.39% duty	High impedance (OFF)	–
Standby	–	–	–	High impedance	High impedance (OFF)	Reset

1. Frequency and duty are typical values.

TYPICAL APPLICATION CIRCUIT

(2 cells)

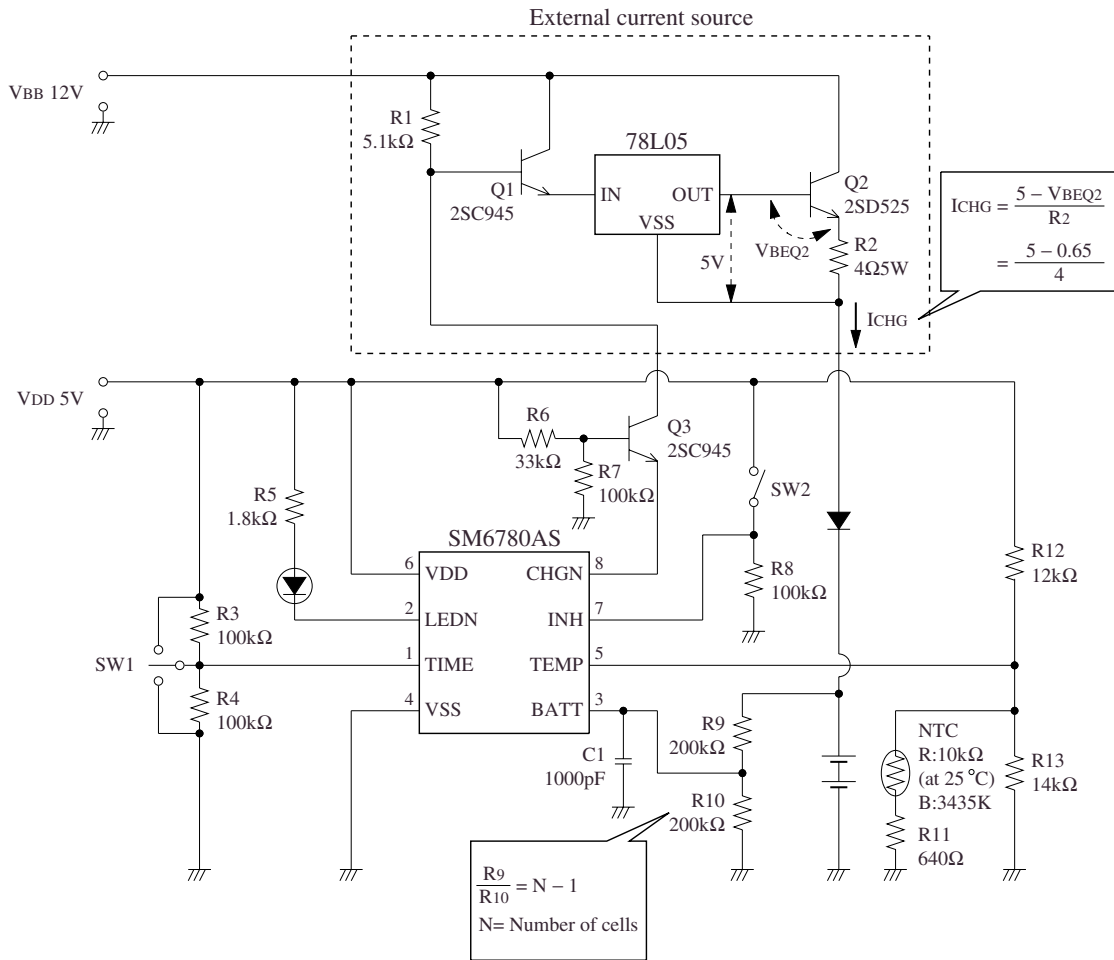

Note that the above circuit is an example circuit to demonstrate the connections for device functions. Battery charger operation is not guaranteed.

Please pay your attention to the following points at time of using the products shown in this document.

The products shown in this document (hereinafter "Products") are not intended to be used for the apparatus that exerts harmful influence on human lives due to the defects, failure or malfunction of the Products. Customers are requested to obtain prior written agreement for such use from SEIKO NPC CORPORATION (hereinafter "NPC"). Customers shall be solely responsible for, and indemnify and hold NPC free and harmless from, any and all claims, damages, losses, expenses or lawsuits, due to such use without such agreement. NPC reserves the right to change the specifications of the Products in order to improve the characteristic or reliability thereof. NPC makes no claim or warranty that the contents described in this document dose not infringe any intellectual property right or other similar right owned by third parties. Therefore, NPC shall not be responsible for such problems, even if the use is in accordance with the descriptions provided in this document. Any descriptions including applications, circuits, and the parameters of the Products in this document are for reference to use the Products, and shall not be guaranteed free from defect, inapplicability to the design for the mass-production products without further testing or modification. Customers are requested not to export or re-export, directly or indirectly, the Products to any country or any entity not in compliance with or in violation of the national export administration laws, treaties, orders and regulations. Customers are requested appropriately take steps to obtain required permissions or approvals from appropriate government agencies.

The logo for NPC (Seiko NPC Corporation) consists of the letters 'NPC' in a bold, black, sans-serif font. The 'N' and 'P' are connected at the top, and the 'C' is positioned to the right of the 'P'.

**SEIKO NPC CORPORATION**

15-6, Nihombashi-kabutocho, Chuo-ku,  
Tokyo 103-0026, Japan  
Telephone: +81-3-6667-6601  
Facsimile: +81-3-6667-6611  
<http://www.npc.co.jp/>  
Email: [sales@npc.co.jp](mailto:sales@npc.co.jp)

NC9918EE 2007.07