

OVERVIEW

The SM8145A is an Electro Luminescent (EL) driver IC that can drive two EL displays simultaneously. Each EL display mode ON/OFF function can be separately controlled using two enable (ENA) pins. The luminance in each display mode can be adjusted, enabling the luminance and consumption current to be optimized to match the application. The device is supplied in ultra-small leadless QFN-20 packages, making driver circuit miniaturization possible.

FEATURES

- 2 separate EL display drivers
- 2-display simultaneous driver operation
- Adjustable luminance and current consumption in each mode
- 3 display modes and a standby mode select control pins (ENA1, ENA2)
- 1 to 30cm² EL display size per channel
- 1.6 to 5.5V supply voltage
- 200Vp-p maximum EL driver voltage
- 20-pin QFN ultra-small leadless package
- High voltage CMOS Process

APPLICATIONS

- Mobile phone
- PDA, Handheld PC
- Illumination accessory

ORDERING INFORMATION

Device	Package
SM8145AB	20-pin QFN

PINOUT

(Top view)

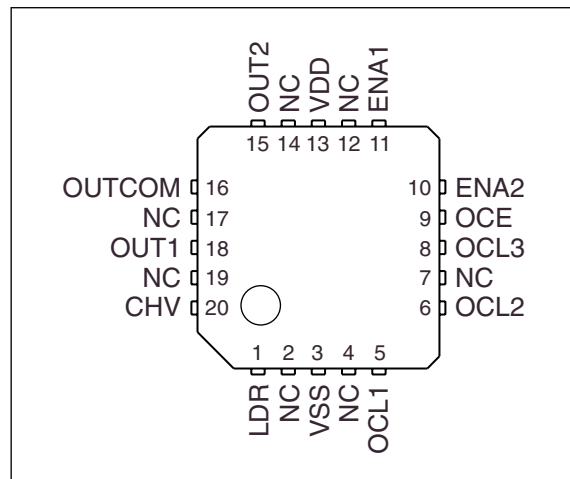

PACKAGE DIMENSIONS

(Unit : mm)

Weight : 0.037g

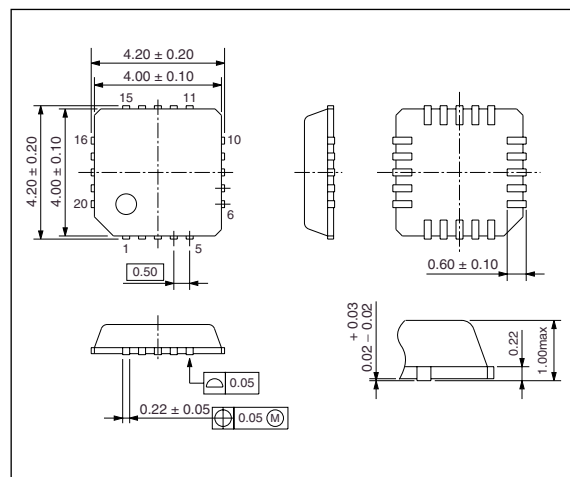

BLOCK DIAGRAM

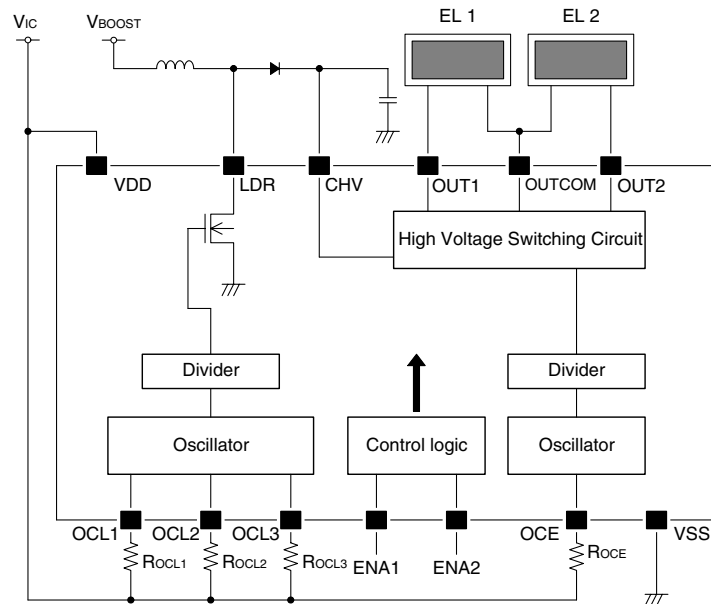

PIN DESCRIPTION

Pin number	Name	I/O	Function
1	LDR	O	Booster coil driver output
2	NC	–	No connection (must be open)
3	VSS	–	Ground
4	NC	–	No connection (must be open)
5	OCL1	I	Coil driver oscillator 1 (oscillator frequency determined by external resistor)
6	OCL2	I	Coil driver oscillator 2 (oscillator frequency determined by external resistor)
7	NC	–	No connection (must be open)
8	OCL3	I	Coil driver oscillator 3 (oscillator frequency determined by external resistor)
9	OCE	I	EL driver oscillator (oscillator frequency determined by external resistor)
10	ENA2	Ip ¹	Enable input 2 (HIGH: enable, LOW: disable)
11	ENA1	Ip ¹	Enable input 1 (HIGH: enable, LOW: disable)
12	NC	–	No connection (must be open)
13	VDD	–	Supply
14	NC	–	No connection (must be open)
15	OUT2	O	Output 2
16	OUTCOM	O	Output (common)
17	NC	–	No connection (must be open)
18	OUT1	O	Output 1
19	NC	–	No connection (must be open)
20	CHV	I	High-voltage DC input

1. Built-in pull-down resistor.

SPECIFICATIONS

Absolute Maximum Ratings

Parameter	Symbol	Condition	Rating	Unit
Supply voltage range	V_{DD}		- 0.3 to 7.0	V
Input voltage range	V_{IN}	All Input pins	$V_{SS} - 0.3$ to $V_{DD} + 0.3$	V
Output voltage	V_{CHV}	CHV pin	0.5 to 120	V
	V_{LDR}	LDR pin	0.5 to 120	V
	$V_{OUT1/2/COM}$	OUT1, OUT2, OUTCOM pin	0.5 to 120	V
Power dissipation	P_D	$T_a \leq 70^\circ\text{C}$	140	mW
		$T_a \leq 85^\circ\text{C}$	100	mW
Storage temperature range	T_{STG}		- 55 to 125	$^\circ\text{C}$

Recommended Operating Conditions

Parameter	Symbol	Condition	Rating			Unit
			min	typ	max	
Supply voltage range	V_{DD2}		1.6	3.0	5.5	V
Operating temperature	T_{OPR}		- 40	-	85	$^\circ\text{C}$
Operating current ¹	I_{DD2}	Including coil current, $V_{DD} = 3.0\text{V}$, $T_a \leq 70^\circ\text{C}$	-	-	85	mA
		Including coil current, $V_{DD} = 5.0\text{V}$, $T_a \leq 70^\circ\text{C}$	-	-	51	mA
		Including coil current, $V_{DD} = 3.0\text{V}$, $T_a \leq 85^\circ\text{C}$	-	-	60	mA
		Including coil current, $V_{DD} = 5.0\text{V}$, $T_a \leq 85^\circ\text{C}$	-	-	36	mA
Coil inductance	L_{LDR}	$f_{LDR} = 64\text{kHz}$	-	0.47	-	mH

1. Max value is as same as Absolute Maximum Ratings.

DC Characteristics

$V_{DD} = 3.0V$, $T_a = 25^\circ C$ unless otherwise noted.

Parameter	Symbol	Condition	Rating			Unit
			min	typ	max	
Supply voltage	V_{DD}		1.6	3.0	5.5	V
CHV output voltage	V_{CHV}		0.5	–	100	V
OUT1, OUT2, OUTCOM HIGH-level output voltage	V_{OUTH}		–	–	100	V
OUT1, OUT2, OUTCOM LOW-level output voltage	V_{OUTL}		–	–	0.5	V
LDR output resistance	R_{LDR}	$I_{LDR} = 50mA$	–	8.0	12.0	Ω
OCE oscillator frequency	f_{OCE1}	$R_{OCE} = 180k\Omega$	205	256	307	kHz
OCE oscillator frequency range	f_{OCE2}		32	–	1536	
OCL1, OCL2, OCL3 oscillator frequency	f_{OCL1}	$R_{OCL} = 180k\Omega$	205	256	307	kHz
OCL1, OCL2, OCL3 oscillator frequency range	f_{OCL2}		32	–	1536	
OUT1, OUT2, OUTCOM output frequency	f_{OUT1}	$R_{OCE} = 180k\Omega$	200	250	300	Hz
OUT1, OUT2, OUTCOM output frequency range	f_{OUT2}		31	–	1500	
LDR inductance driver frequency	f_{LDR1}	$R_{OCL} = 180k\Omega$	51	64	77	kHz
LDR inductance driver frequency range	f_{LDR2}		8	–	384	
ENA1, ENA2 HIGH-level input voltage	V_{ENAH}	ENA = HIGH, $V_{DD} = 1.6$ to $5.5V$	$V_{DD} - 0.5$	–	$V_{DD} + 0.3$	V
ENA1, ENA2 LOW-level input voltage	V_{ENAL}	ENA = LOW, $V_{DD} = 1.6$ to $5.5V$	$V_{SS} - 0.3$	–	$V_{SS} + 0.5$	
ENA1, ENA2 input current	I_{ENAH}	$V_{ENAH} = V_{DD} = 3.0V$	2.0	4.0	6.0	μA
ENA1, ENA2 rise time ¹	t_{ENA}		–	–	100	ms
Operating current	I_{DD1}	Excluding coil current	–	–	1.0	mA
Stand-by current	I_{STB}	ENA = LOW	–	–	1.0	μA

1.

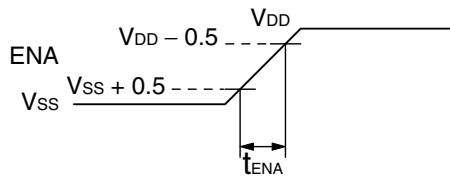

FUNCTIONAL DESCRIPTION

DISPLAY MODES

Operation mode	ENA input		OUTPUT status			Brightness adjust
	ENA1	ENA2	OUTCOM	OUT1	OUT2	ROCL
Standby	L	L	L	L	L	–
EL1	H	L	Active	Active	Hi-Z	R_{OCL1}
EL2	L	H	Active	Hi-Z	Active	R_{OCL2}
EL1 + EL2	H	H	Active	Active	Active	R_{OCL3}

Notes) The internal oscillator resistance is selected in response to the state of the ENA pins.

The oscillator resistance ($R_{OCE1/2/3}$) adjust the luminance in each display mode, respectively.

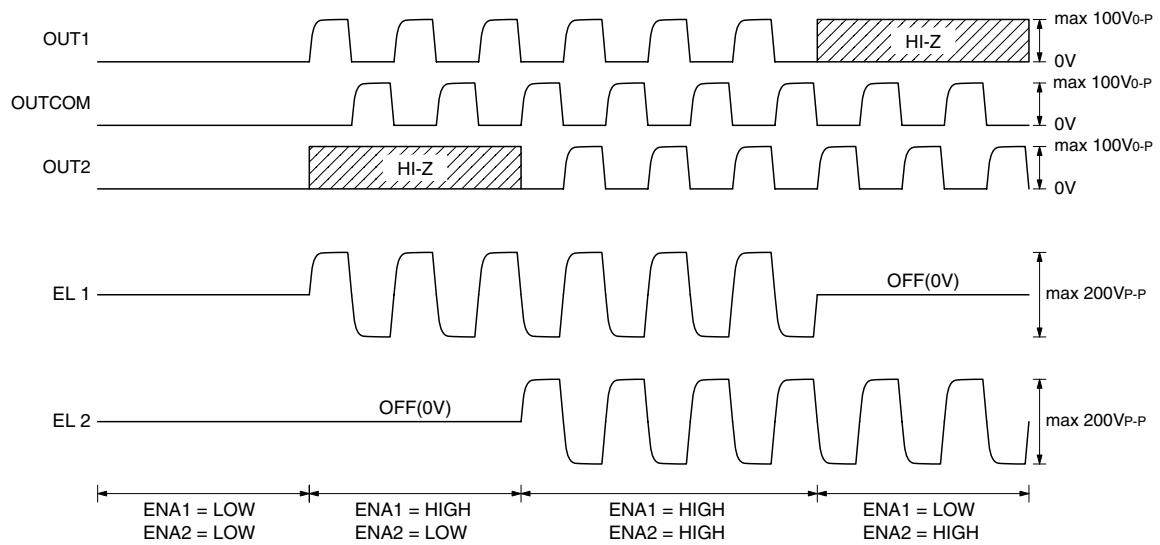

TYPICAL APPLICATIONS

- EL size: 20 + 20cm², Current consumption: 20 + 20mA

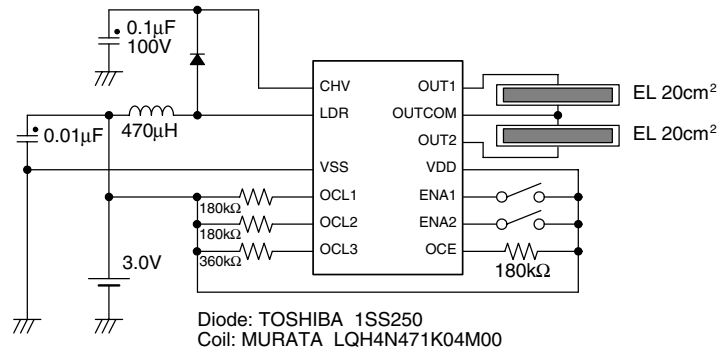

- EL size: 20 + 30cm², Current consumption: 20 + 30mA

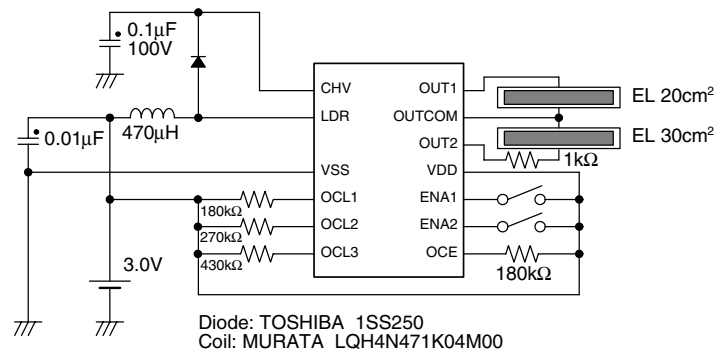

- EL size: 10 + 30cm², Current consumption: 10 + 30mA

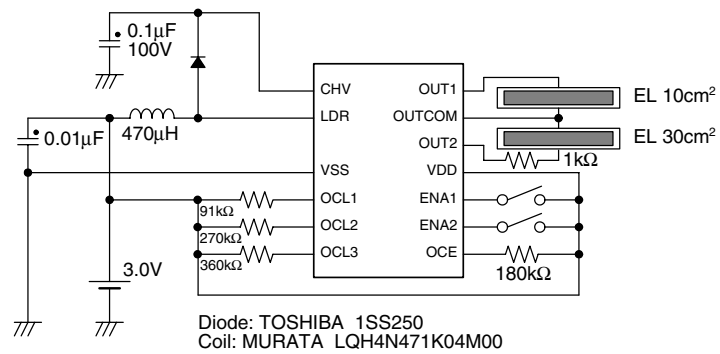

Note: Connect a 1kΩ resistor to protect IC when the EL is over 20cm² per channel.
Note: Do not operate the SM8145A with the EL NOT connected (no load to OUTCOM/OUT1/OUT2) since the IC will be damaged.

Please pay your attention to the following points at time of using the products shown in this document.

The products shown in this document (hereinafter "Products") are not intended to be used for the apparatus that exerts harmful influence on human lives due to the defects, failure or malfunction of the Products. Customers are requested to obtain prior written agreement for such use from SEIKO NPC CORPORATION (hereinafter "NPC"). Customers shall be solely responsible for, and indemnify and hold NPC free and harmless from, any and all claims, damages, losses, expenses or lawsuits, due to such use without such agreement. NPC reserves the right to change the specifications of the Products in order to improve the characteristic or reliability thereof. NPC makes no claim or warranty that the contents described in this document dose not infringe any intellectual property right or other similar right owned by third parties. Therefore, NPC shall not be responsible for such problems, even if the use is in accordance with the descriptions provided in this document. Any descriptions including applications, circuits, and the parameters of the Products in this document are for reference to use the Products, and shall not be guaranteed free from defect, inapplicability to the design for the mass-production products without further testing or modification. Customers are requested not to export or re-export, directly or indirectly, the Products to any country or any entity not in compliance with or in violation of the national export administration laws, treaties, orders and regulations. Customers are requested appropriately take steps to obtain required permissions or approvals from appropriate government agencies.

The logo for SEIKO NPC CORPORATION, consisting of the letters 'NPC' in a bold, black, sans-serif font.

SEIKO NPC CORPORATION

15-6, Nihombashi-kabutocho, Chuo-ku,
Tokyo 103-0026, Japan
Telephone: +81-3-6667-6601
Facsimile: +81-3-6667-6611
<http://www.npc.co.jp/>
Email: sales@npc.co.jp

NC0001CE 2006.04